



US 20220347680A1

(19) **United States**

(12) **Patent Application Publication**

Wernerehl et al.

(10) **Pub. No.: US 2022/0347680 A1**

(43) **Pub. Date: Nov. 3, 2022**

(54) **ASSAY DEVICES AND METHODS OF MANUFACTURE**

Related U.S. Application Data

(60) Provisional application No. 62/927,481, filed on Oct. 29, 2019.

(71) Applicant: **bioMerieux, Inc.**, Durham, NC (US)

Publication Classification

(72) Inventors: **Aaron Wernerehl**, Salt Lake City, UT (US); **Jonathan A. Bruns**, Salt Lake City, UT (US); **Jonathan B. Derrick**, Draper, UT (US); **Taylor S. Zimmerman**, West Valley City, UT (US); **David E. Jones**, Layton, UT (US)

(51) **Int. Cl.**
B01L 3/00 (2006.01)
B01L 7/00 (2006.01)
B29D 22/00 (2006.01)
(52) **U.S. Cl.**
CPC *B01L 3/502707* (2013.01); *B01L 7/52* (2013.01); *B29D 22/00* (2013.01); *B01L 2200/16* (2013.01); *B01L 2300/18* (2013.01); *B01L 2300/0887* (2013.01); *B01L 2400/0683* (2013.01); *B29K 2105/256* (2013.01)

(21) Appl. No.: **17/771,965**

(22) PCT Filed: **Oct. 28, 2020**

(86) PCT No.: **PCT/US20/57600**

§ 371 (c)(1),

(2) Date: **Apr. 26, 2022**

(57) **ABSTRACT**

Systems, methods, and apparatuses are provided for self-contained nucleic acid preparation, amplification, and analysis.

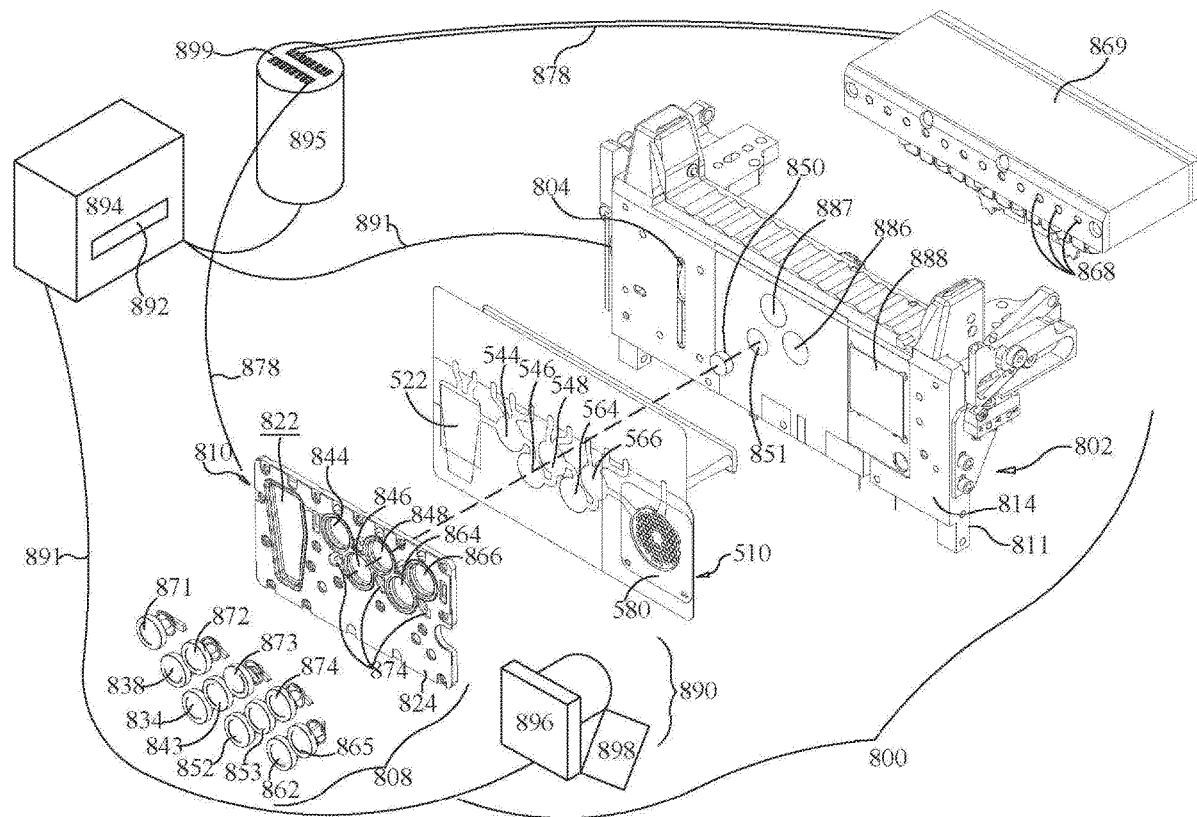

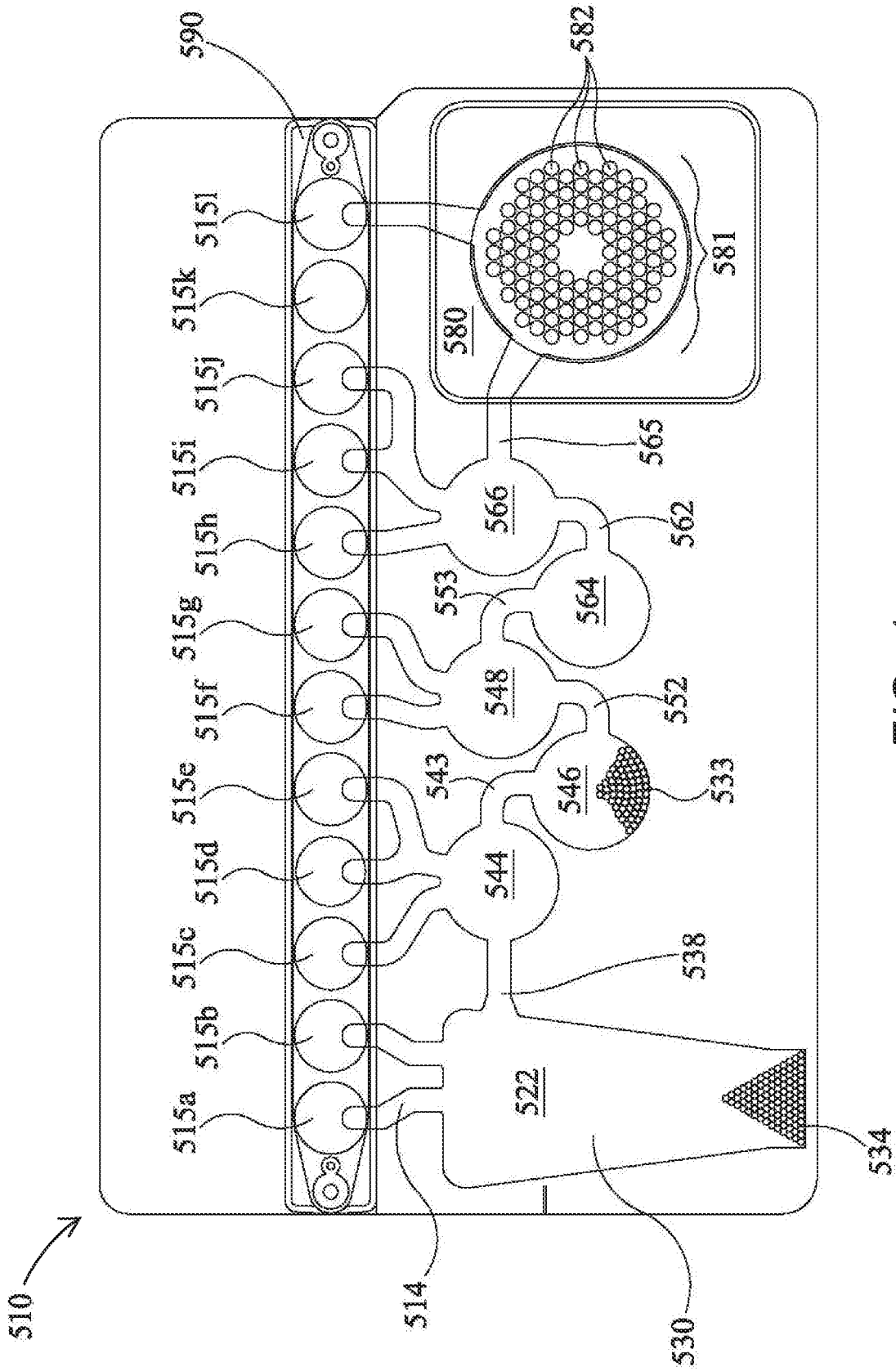

FIG. 1

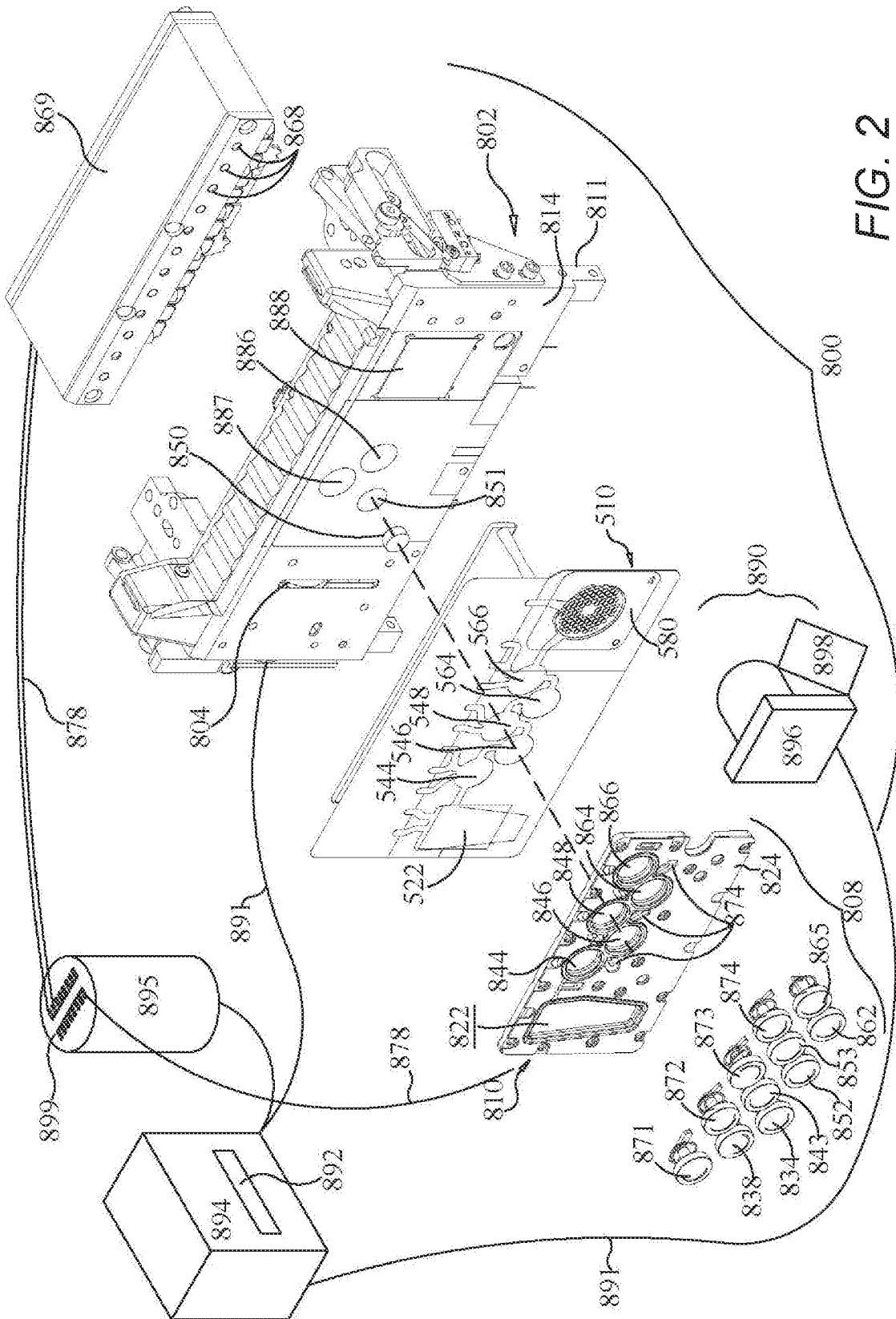

FIG. 2

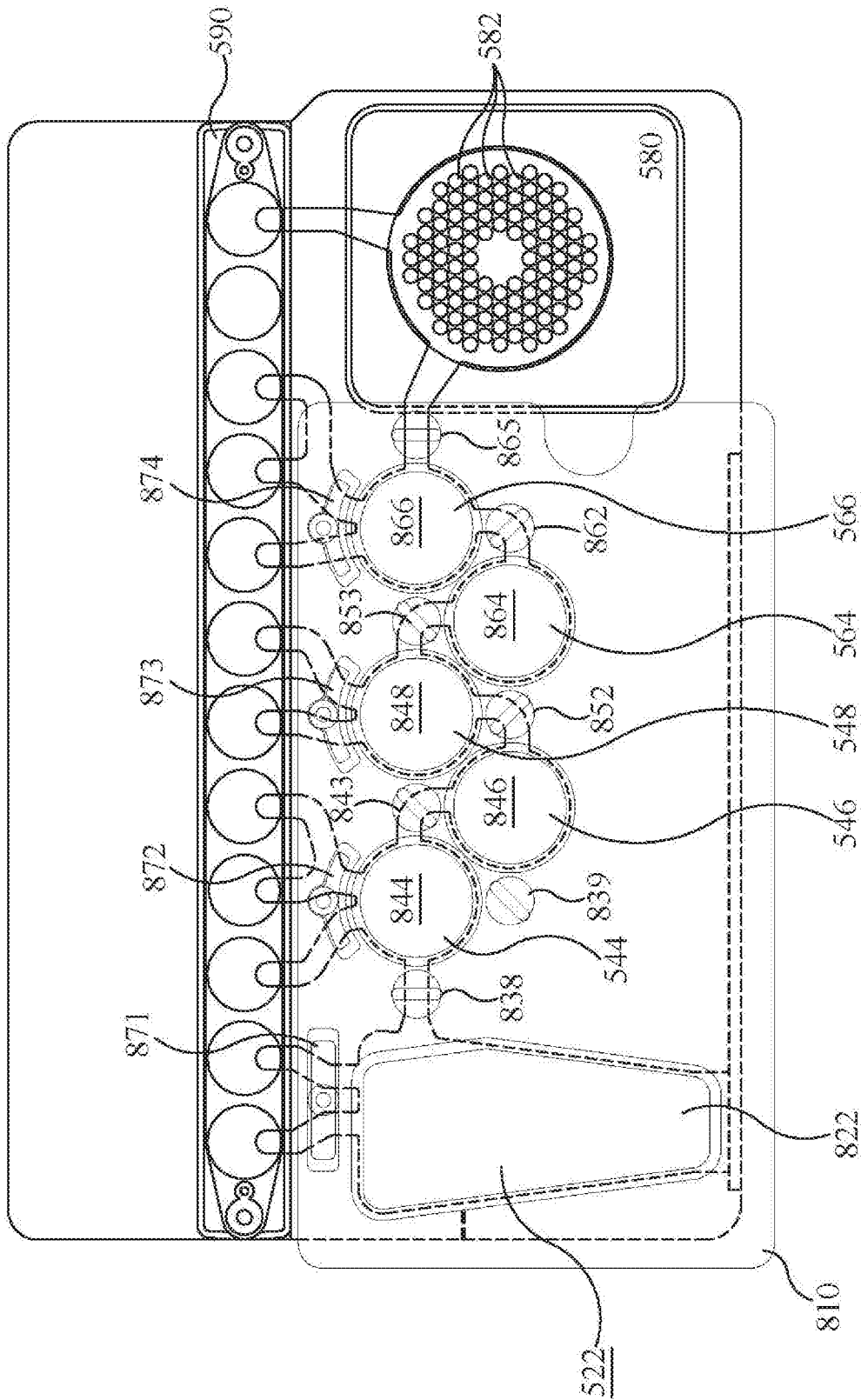

FIG. 3

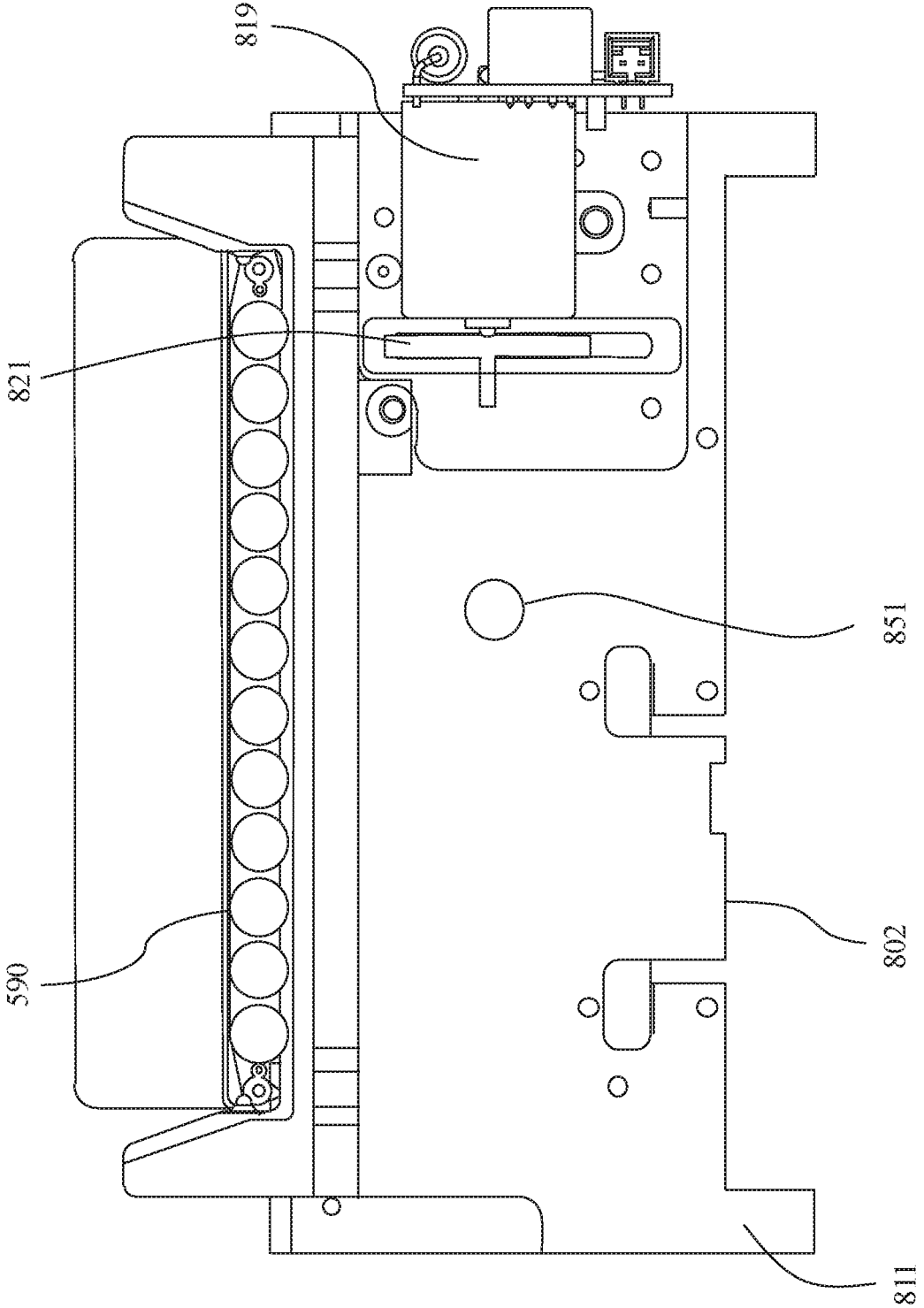

FIG. 4

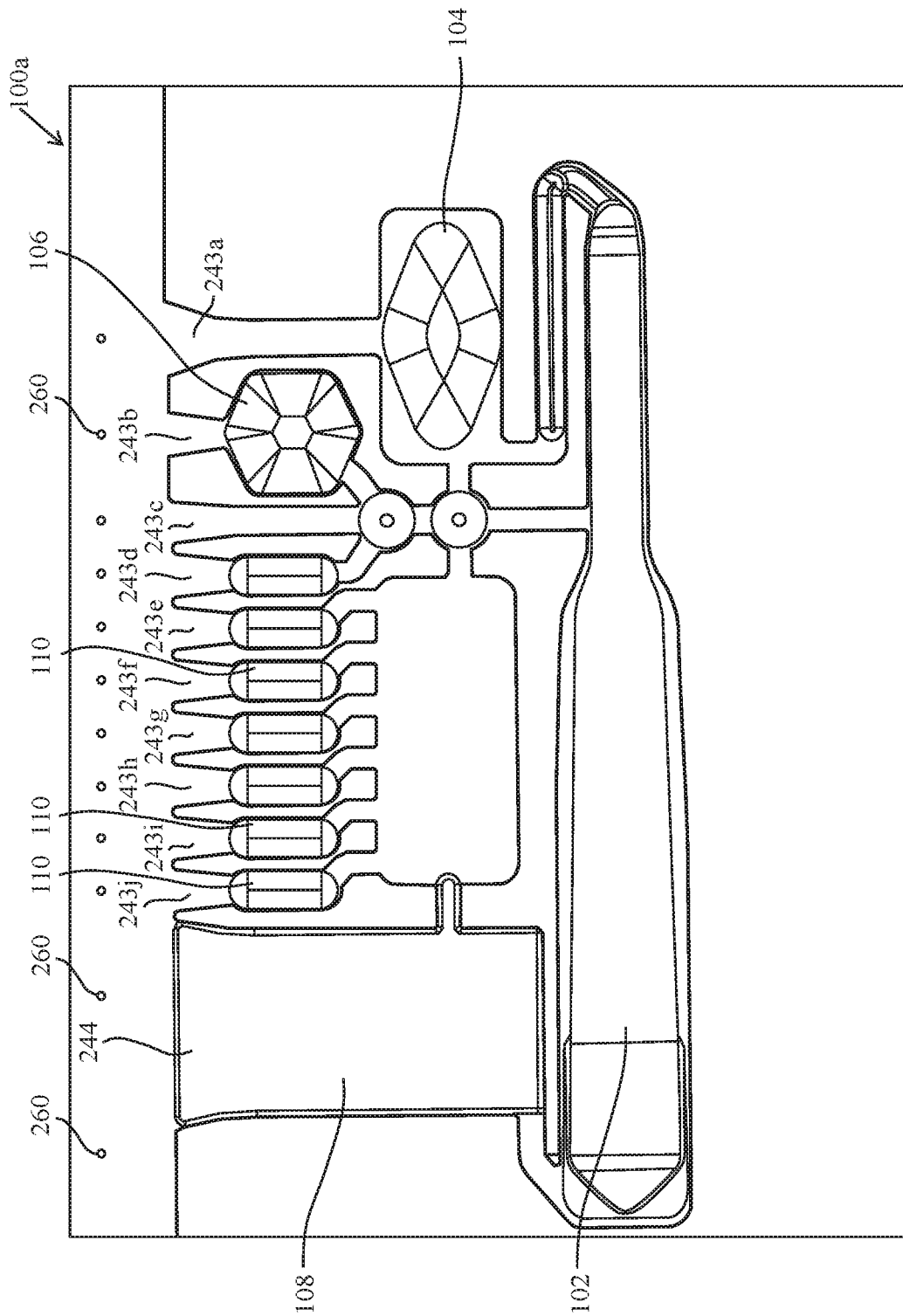

FIG. 5A

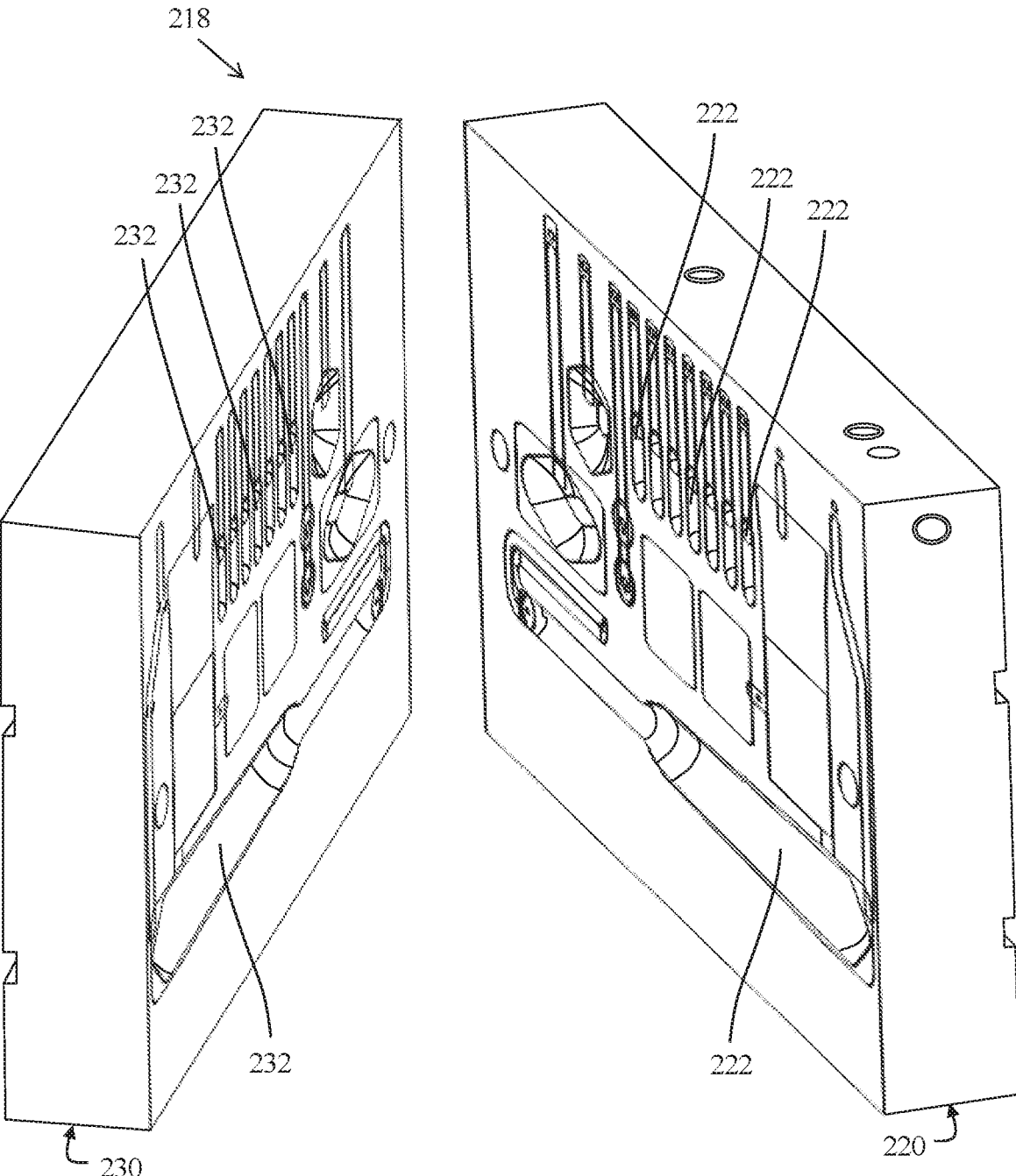

FIG. 6

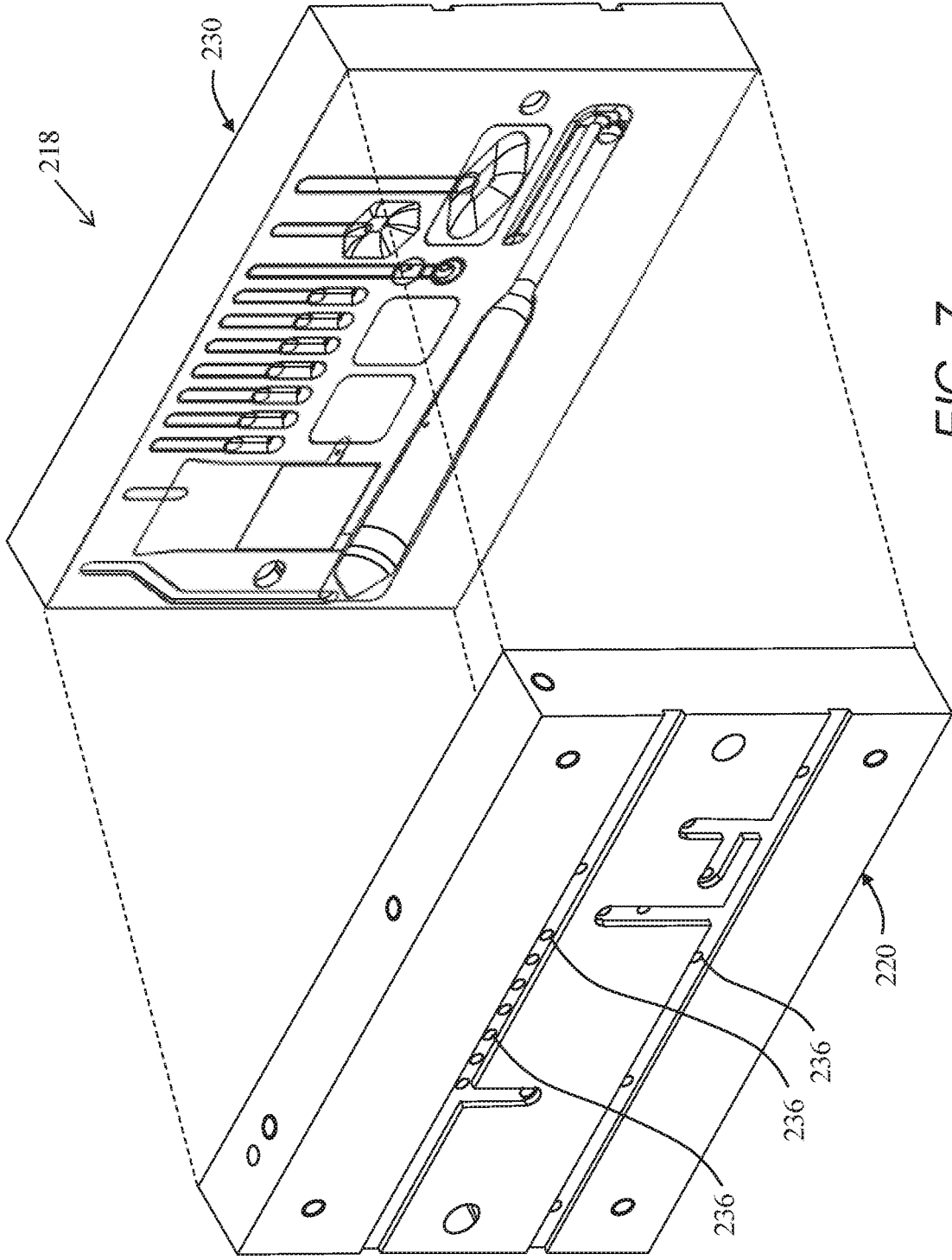

FIG. 7

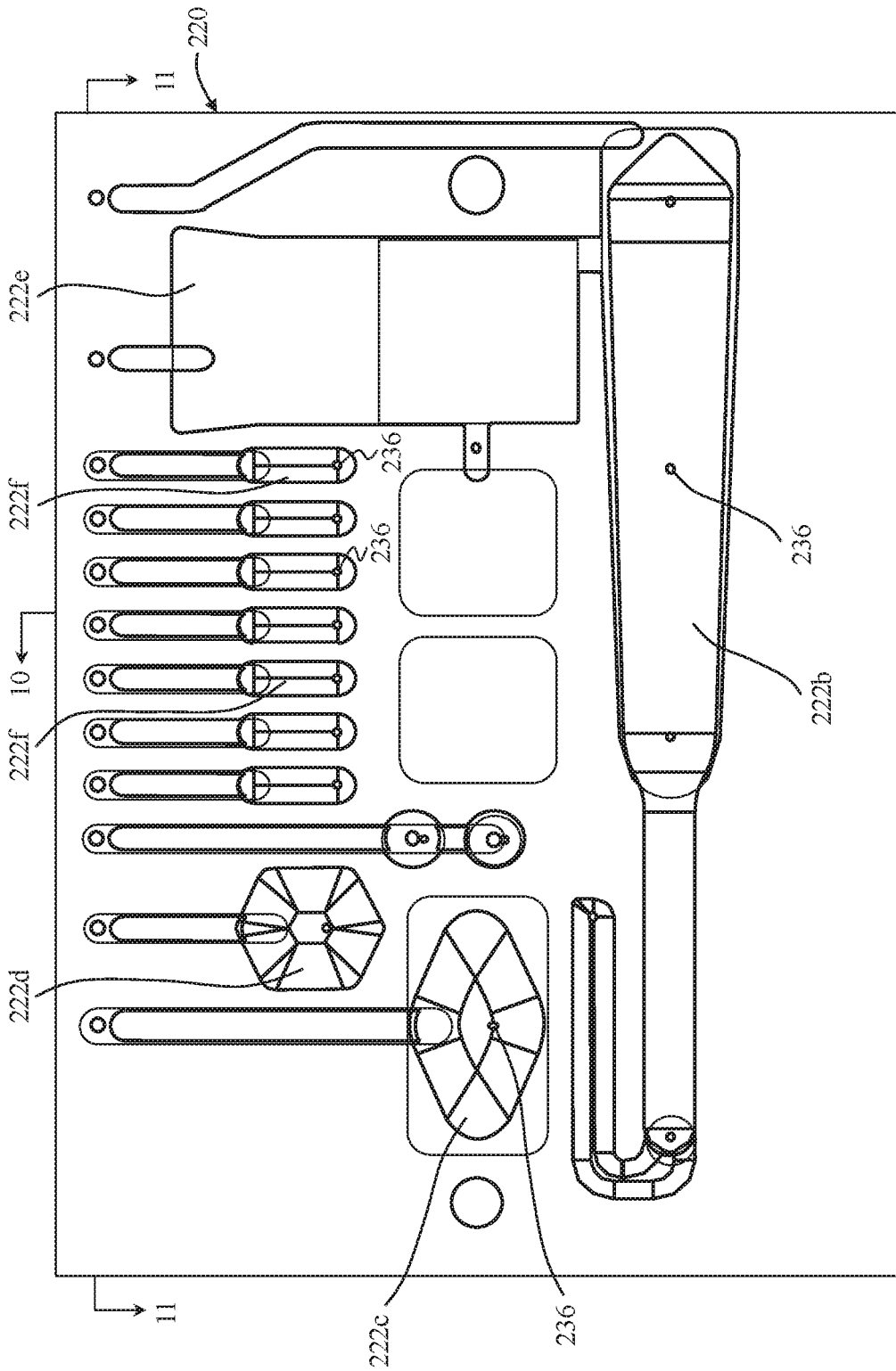

FIG. 8

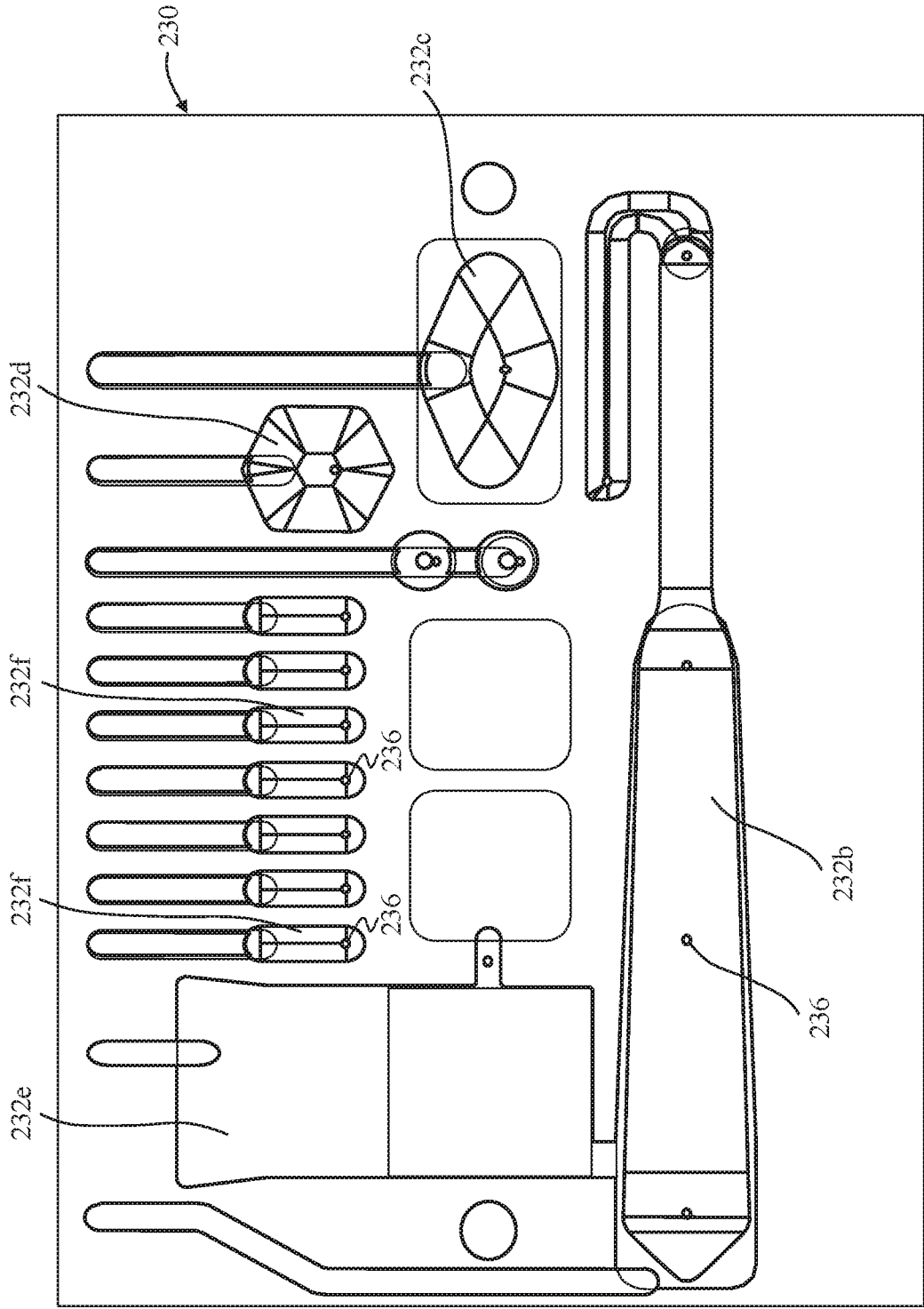

FIG. 9

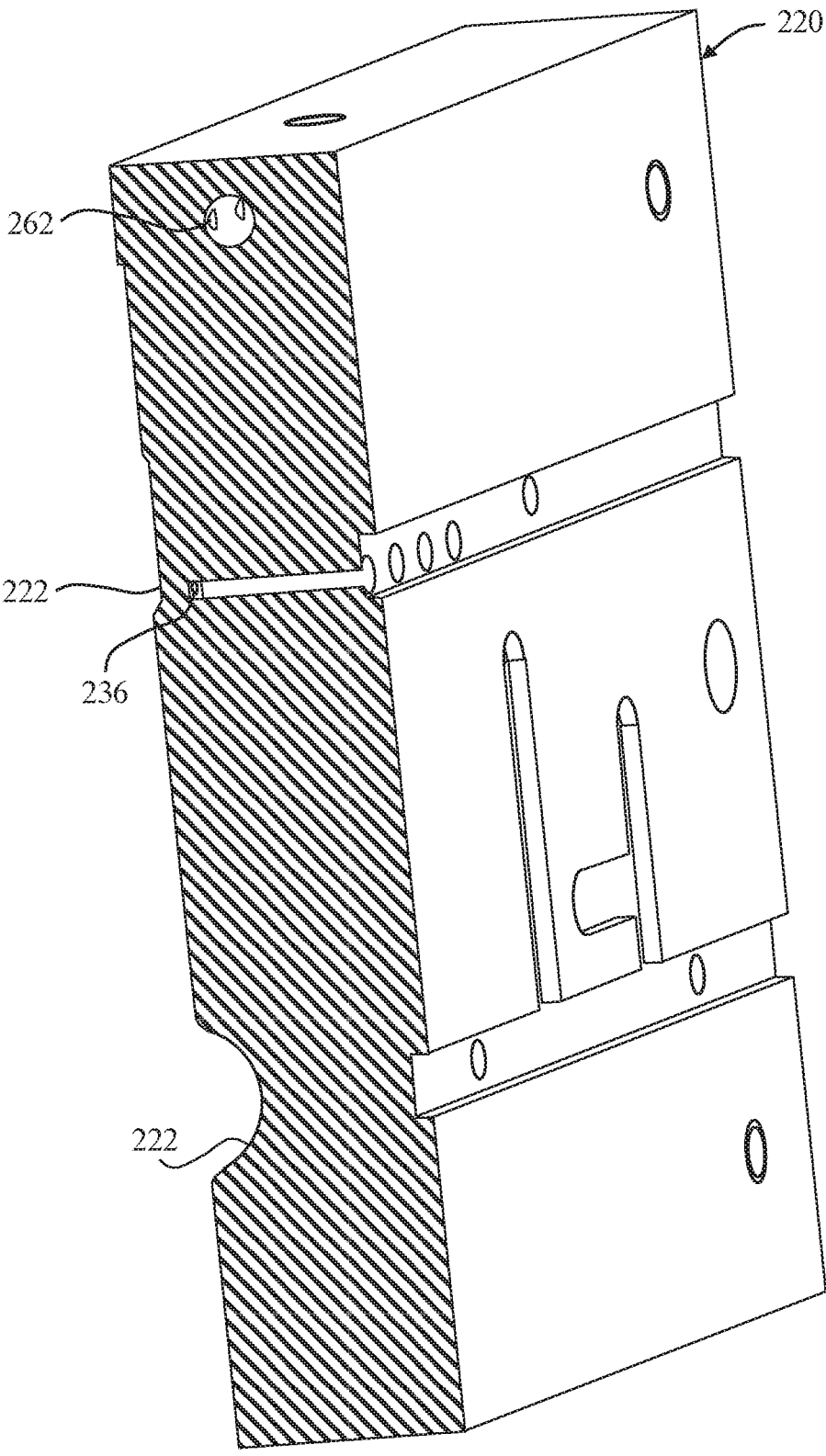

FIG. 10

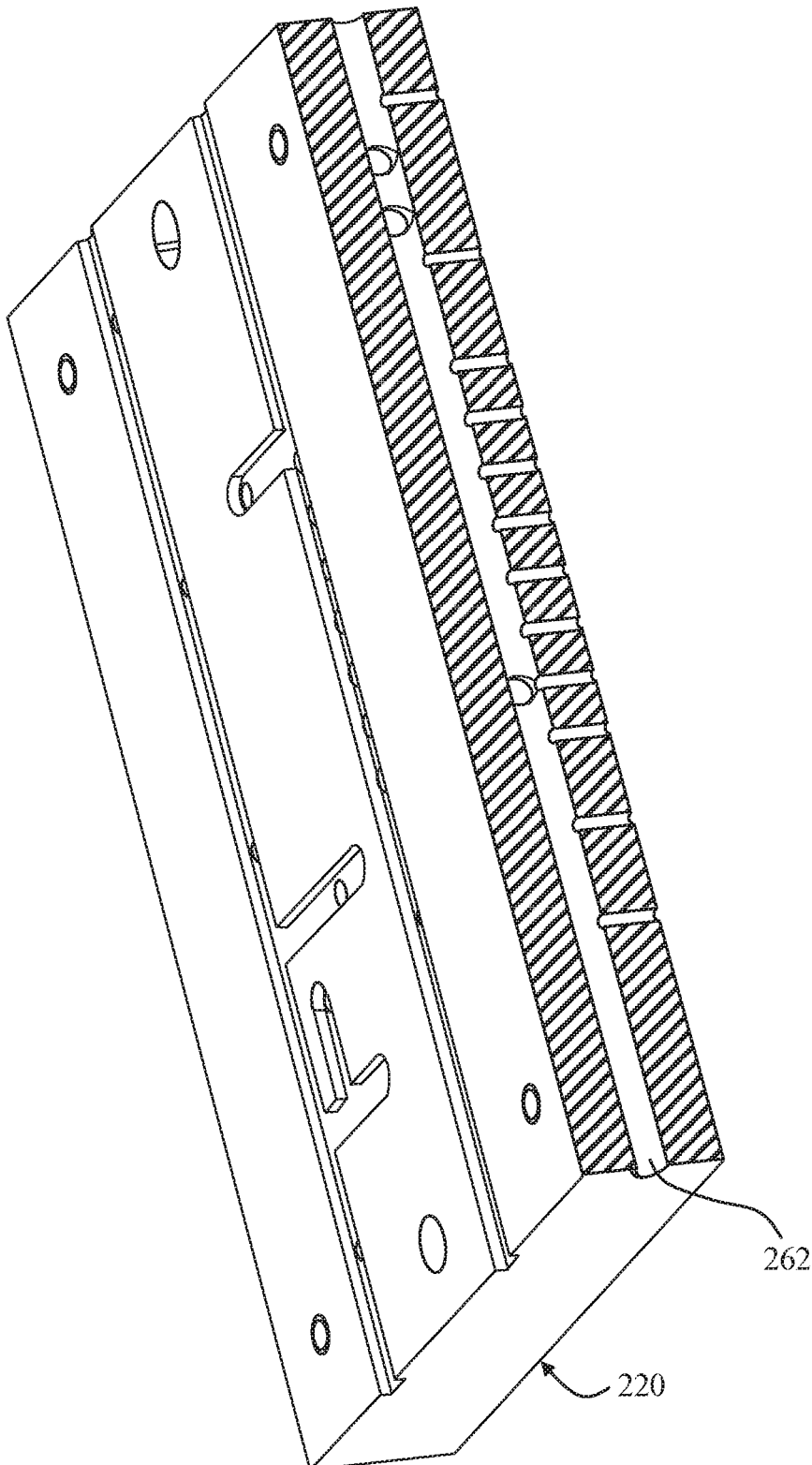

FIG. 11

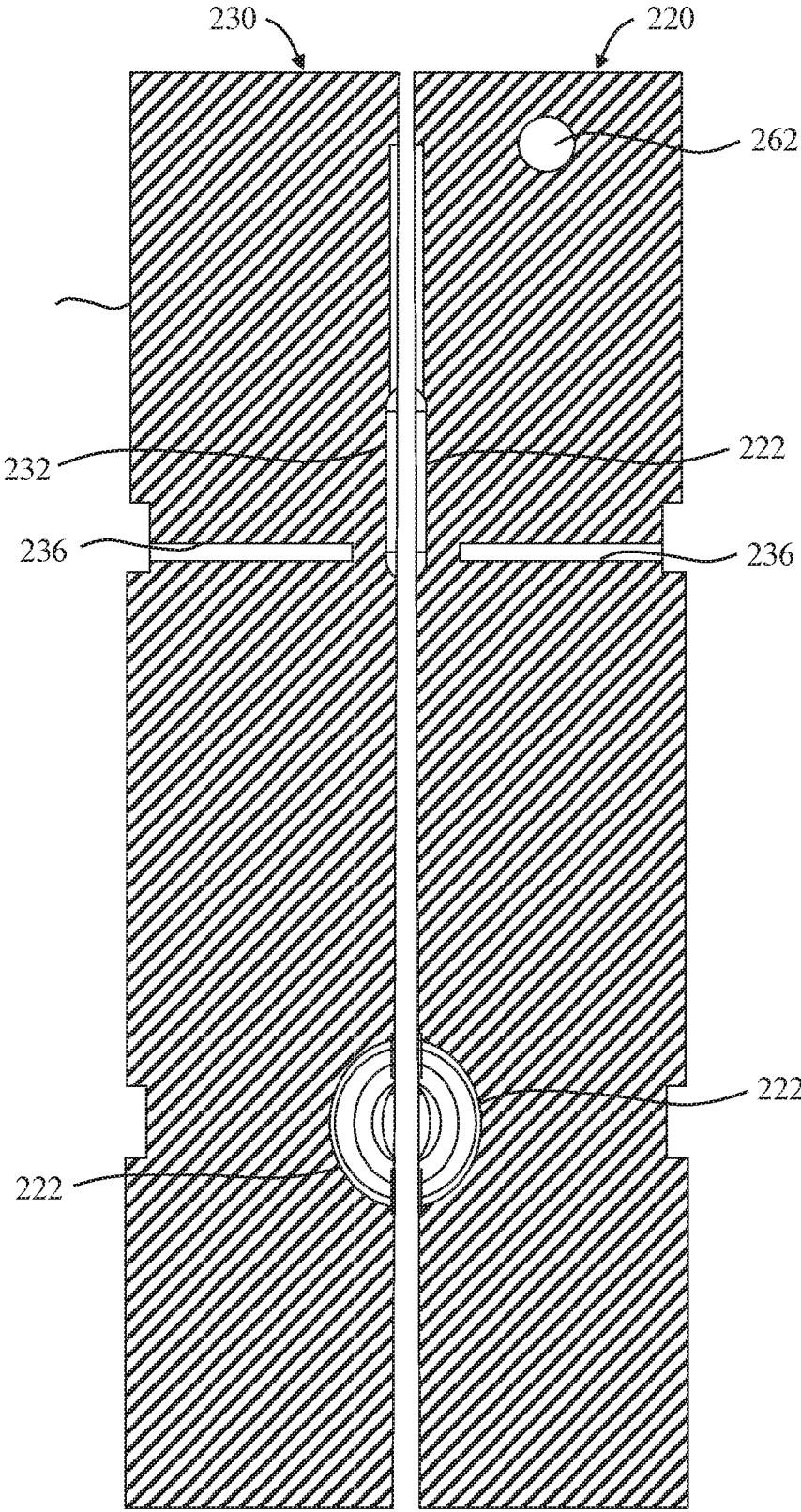

FIG. 12

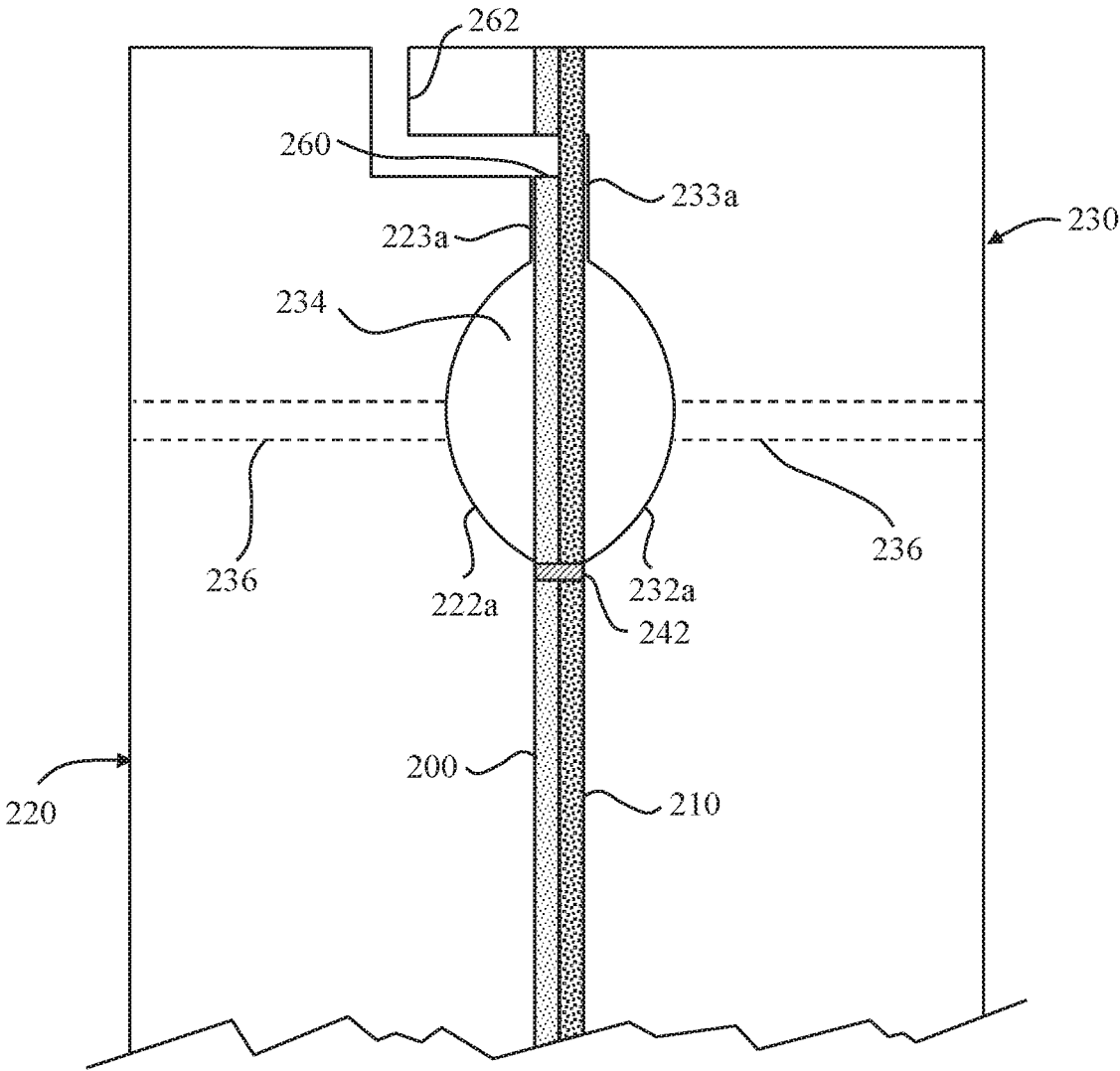

FIG. 13

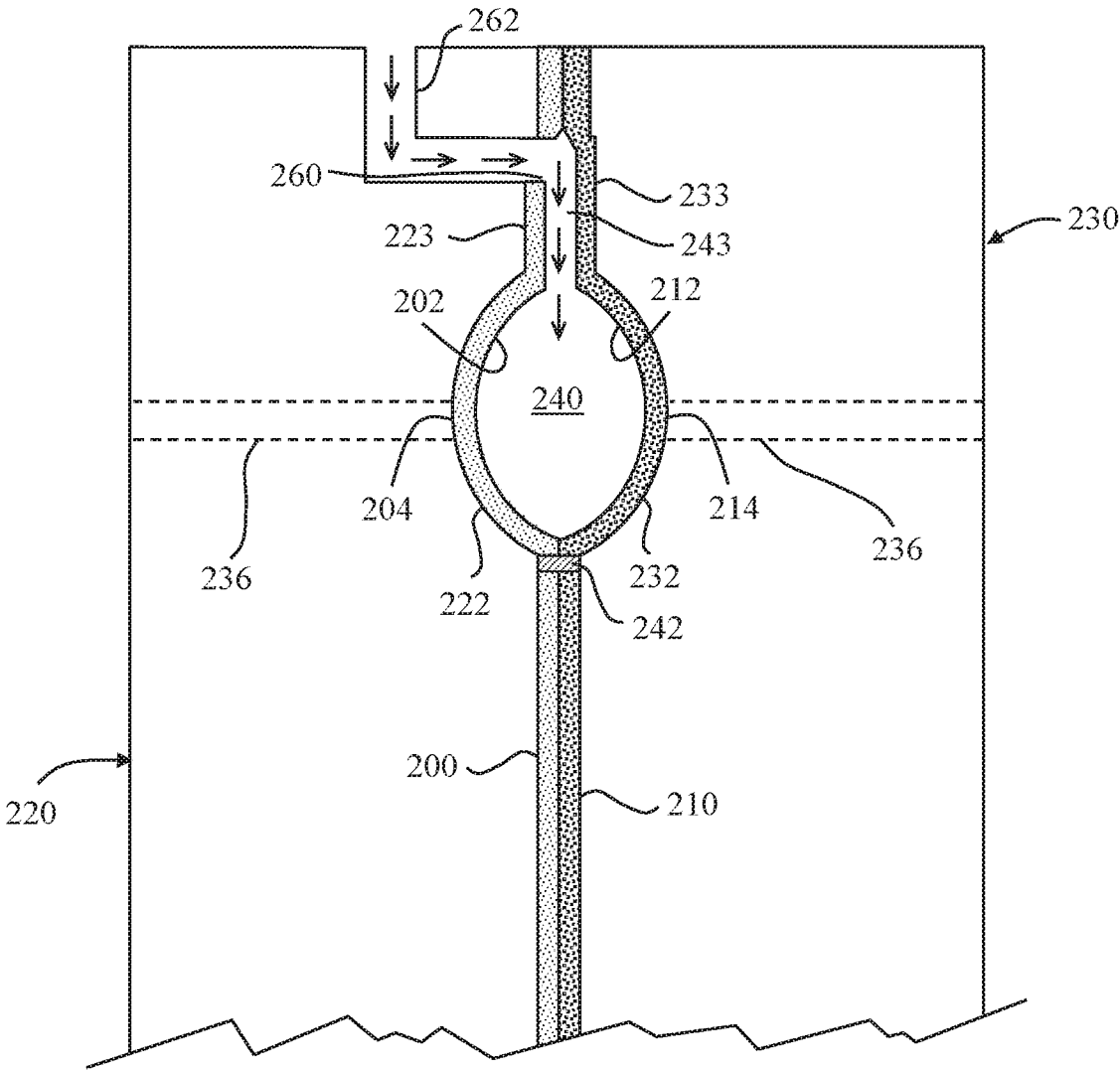

FIG. 14

ASSAY DEVICES AND METHODS OF MANUFACTURE

CROSS REFERENCE TO RELATED APPLICATIONS

[0001] This application claims the benefit of and priority to U.S. Prov. Pat. App. No. 62/927,481 filed 29 Oct. 2019, the entirety of which is incorporated herein by reference. This Application also references French Patent Application FR1912110 filed 29 Oct. 2019, the entirety of which is incorporated herein by reference.

BACKGROUND

1. Technical Field

[0002] Embodiments of the present disclosure relate generally to test devices, for example, for amplifying nucleic acids and methods of manufacture of such test devices.

2. Background

[0003] In the United States, Canada, and Western Europe infectious disease accounts for approximately 7% of human mortality, while in developing regions infectious disease accounts for over 40% of human mortality. Infectious diseases lead to a variety of clinical manifestations. Among common overt manifestations are fever, pneumonia, meningitis, diarrhea, and diarrhea containing blood. While the physical manifestations suggest some pathogens and eliminate others as the etiological agent, a variety of potential causative agents remain, and clear diagnosis often requires a variety of assays be performed. Traditional microbiology techniques for diagnosing pathogens can take days or weeks, often delaying a proper course of treatment.

[0004] In recent years, the polymerase chain reaction (PCR) has become a method of choice for rapid diagnosis of infectious agents. PCR can be a rapid, sensitive, and specific tool to diagnose infectious disease. However, a challenge to using PCR as a primary means of diagnosis is the variety of possible causative organisms or viruses and the low levels of organism or virus present in some pathological specimens. It is often impractical to run large panels of PCR assays, one for each possible causative organism or viruses, most of which are expected to be negative. The problem is exacerbated when pathogen nucleic acid is at low concentration and requires a large volume of sample to gather adequate reaction templates. In some cases there is inadequate sample to assay for all possible etiological agents. A solution is to run "multiplex PCR" wherein the sample is concurrently assayed for multiple targets in a single reaction. While multiplex PCR has proved to be valuable in some systems, shortcomings exist concerning robustness of high level multiplex reactions and difficulties for clear analysis of multiple products. To solve these problems, the assay may be subsequently divided into multiple secondary PCRs. Nesting secondary reactions within the primary product increases robustness. Closed systems such as the FilmArray® (BioFire Diagnostics, LLC, Salt Lake City, Utah) reduce handling, thereby diminishing contamination risk.

[0005] The present invention addresses various improvements relating to automated or semi-automated manufacturing of test devices, cost of test devices, and more rapid sample-to-answer.

BRIEF SUMMARY

[0006] Described herein are self-contained reaction containers (also referred to herein as 'pouches' or 'cards'), methods of manufacturing such reaction containers, instruments, systems, and methods for rapid amplification of nucleic acids. In an illustrative embodiment, a reaction container may be fabricated from a first sheet and a second sheet of polymeric material with one or more fluidically connected reaction chambers and reagent reservoirs (e.g., aqueous reagent reservoirs) formed between the first and second sheets. The reaction chambers and reagent reservoirs may be formed by pressing the first and second polymeric sheets between forming plates and propelling a compressed fluid between the sheets to form open areas.

[0007] Described herein are:

[0008] A1. A method for forming a reaction container, comprising:

[0009] providing a polymeric sheet that comprises an inner planar face and an outer planar face;

[0010] contacting a first inner planar face of the polymeric sheet to a second inner planar face of the polymeric sheet;

[0011] pressing the polymeric sheet between a first forming plate and a second forming plate, wherein at least one of the first or second forming plates has one or more recesses for forming one or more features selected from the group consisting of a reaction chamber, a fluid flow channel, a reagent chamber, or a sample chamber in selected portions of the polymeric sheet;

[0012] propelling a compressed fluid between the inner planar faces of the polymeric sheet while the polymeric sheet is pressed between the forming plates to reform the selected portions of the polymeric sheet into a shape defined by the one or more recesses of the forming plates;

[0013] separating the first forming plate and the second forming plate so the polymeric sheet is no longer pressed between the first and second forming plates; and

[0014] removing the reaction container from between the first forming plate and the second forming plate.

[0015] A2. The method of clause A1, wherein the provided polymeric sheet comprises a first polymeric sheet and a second polymeric sheet, each polymeric sheet having an inner planar face and an outer planar face, and the method further comprising:

[0016] arranging the first and second polymeric sheets so that the inner planar faces are arranged adjacent to one another,

[0017] performing the pressing step, and

[0018] propelling a compressed fluid between the two polymeric sheets while the two polymeric sheets are pressed between the forming plates to reform the selected portions into a shape defined by the one or more recesses of the forming plates.

[0019] A3. The method of any of clauses A1 or A2 further comprising heating the polymeric sheet to a softening temperature prior to the pressing step, performing the pressing and propelling steps, and cooling the polymeric sheet after the propelling step to set the shape defined by the one or more recesses of the forming plates.

[0020] A4. The method of any of clauses A1-A3, wherein the polymeric sheet comprises a flexible polymeric material having a thickness in a range of about 0.02 mm to about 0.1 mm.

[0021] A5. The method of any of clauses A1-A4, wherein the flexible polymeric material is selected from the group

consisting of polyester, polyethylene, polyethylene terephthalate (PET), polycarbonate, polypropylene (PP), polymethylmethacrylate, mixtures, combinations thereof.

[0022] A6. The method of any of clauses A1-A5, wherein the flexible polymeric material comprises a water vapor and/or oxygen barrier material.

[0023] A7. The method of any of clauses A1-A6, wherein the polymeric material has a water vapor transmission rate (WVTR) in a range of about 0.01 g/m²/24 hrs to about 3 g/m²/24 hrs, preferably in a range of about 0.05 g/m²/24 hrs to about 2 g/m²/24 hrs, or more preferably no more than about 1 g/m²/24 hrs, and an oxygen transmission rate in a range of about 0.01 cc/m²/24 hrs to about 2 cc/m²/24 hrs, preferably in a range of about 0.05 cc/m²/24 hrs to about 2 cc/m²/24 hrs, or more preferably no more than about 1 cc/m²/24 hrs.

[0024] A8. The method of any of clauses A1-A7, wherein the flexible polymeric material comprises two or more layers of film material bonded together and the water vapor and/or oxygen barrier comprises at least one of a metalized or ceramic-coated film layer.

[0025] A9. The method of any of clauses A1-A8, wherein the selected portions comprise one or more of a sample input chamber, a sample preparation chamber, a sample reactant recovery/wash chamber, a reaction chamber, or one or more fluid reagent reservoirs.

[0026] A10. The method of any of clauses A1-A9, further comprising heating the polymeric sheet to a first temperature prior to the pressing step.

[0027] A11. The method of any of clauses A1-A10, wherein separating the first forming plate and the second forming plate comprises moving at least one of the first forming plate and the second forming plate.

[0028] A12. The method of any of clauses A1-A11, wherein separating the first forming plate and the second forming plate comprises moving only one of the first forming plate and the second forming plate.

[0029] B1. A method for forming a reaction container, comprising:

[0030] providing a first polymeric sheet and a second polymeric sheet, wherein the first and second polymeric sheets each comprise an inner planar face and an outer planar face;

[0031] contacting the inner planar face of the first polymeric sheet to the inner planar face of the second polymeric sheet;

[0032] laminating the first polymeric sheet to the second polymeric sheet;

[0033] making one or more seal lines joining the first and second polymeric sheets;

[0034] pressing the first and second polymeric sheets between a first forming plate and a second forming plate, wherein at least one of the first or second forming plates has one or more recesses positioned for reforming the first and second polymeric sheets to form one or more openings in a region defined by the one or more seal lines;

[0035] expanding selected areas of the first and second polymeric sheets into a shape defined by the one or more recesses of the forming plates by blowing a compressed gas between the first and second polymeric sheets while the first and second polymeric sheets are pressed between the forming plates;

[0036] separating the first forming plate and the second forming plate; and

[0037] removing the reaction container from between the first forming plate and the second forming plate.

[0038] B2. The method of clause B1, further comprising cooling the first and second polymeric sheets subsequent to the expanding step to set the shape defined by the one or more recesses of the forming plates.

[0039] B3. The method of any of clauses B1 or B2, wherein the compressed gas blown between the first and second polymeric sheets substantially simultaneously expands and cools the first and second polymeric sheets.

[0040] B4. The method of any of clauses B1-B3, wherein making the one or more seal lines comprises defining one or more of a sample input chamber, a sample preparation chamber, a sample reactant recovery/wash chamber, at least one reaction chamber, a one or more fluid reagent reservoirs, or one or more channels fluidically connecting the sample input chamber, the sample preparation chamber, the sample reactant recovery/wash chamber, the at least one reaction chamber, and the one or more reagent reservoirs.

[0041] B5. The method of any of clauses B1-B4, wherein when the first and second polymeric sheets are pressed between a first forming plate and a second forming plate the one or more recesses of the forming plates substantially align with the one or more areas defined by the seal lines, and the selected areas expanded by blowing a compressed gas between the first and second polymeric sheets comprise one or more of the sample input chamber, the sample preparation chamber, the recovery/wash chamber, one or more reaction chambers, or one or more reagent reservoirs, and wherein one or more of the selected areas expanded by blowing the compressed gas between the first and second polymeric sheets are connected by one or more sealed, openable laminated channels.

[0042] B6. The method of any of clauses B1-B5, wherein the reaction container comprises sample input chamber fluidically connected to a first reaction chamber, a second reaction chamber fluidically connected to the first reaction chamber, and at least one reagent reservoir fluidically connected to the sample input chamber, the first reaction chamber, or the second reaction chamber, and wherein the method further comprises:

[0043] expanding the sample input chamber and the at least one reagent reservoir into shapes defined by the recesses of the forming plates by blowing the compressed gas between the first and second polymeric sheets while the first and second polymeric sheets are pressed between the forming plates.

[0044] B7. The method of any of clauses B1-B6, further comprising expanding the second reaction chamber into a shape defined by the recesses of the forming plates by blowing the compressed gas between the first and second polymeric sheets while the first and second polymeric sheets are pressed between the forming plates.

[0045] B8. The method of any of clauses B1-B7, further comprising:

[0046] making the one or more seal lines defining a second reaction chamber,

[0047] expanding the second reaction chamber into a shape defined by a second reaction chamber recess of the forming plates,

[0048] providing a reaction card having a plurality of wells formed therein and spotted with one or more dried reagents for a second stage reaction,

[0049] inserting the reaction card into the second reaction chamber via an opening between the first and second sheets;

[0050] bonding a first planar face of the reaction card to the first sheet and a second, opposite planar face of the reaction card to the second sheet, and

[0051] sealing the opening used to insert the reaction card by sealing the first polymeric sheet to the second polymeric sheet at the opening.

[0052] B9. The method of any of clauses B1-B8, further comprising:

[0053] injecting a selected aqueous reagent into the at least one reagent reservoir via a reagent reservoir opening between the first and second polymeric sheets, sealing the selected aqueous reagent in the at least one reagent reservoir by sealing

[0054] the first polymeric sheet to the second polymeric sheet at the reagent reservoir opening such that the reaction container is provided with an aqueous reagent at the time of manufacture.

[0055] B10. The method of any of clauses B1-B9, further comprising:

[0056] expanding a fluid reservoir and an access channel in the first reaction chamber into shapes defined by the recesses of the forming plates by blowing the compressed gas between the first and second polymeric sheets while the first and second polymeric sheets are pressed between the forming plates,

[0057] injecting an aqueous reagent into the fluid reservoir in the first reaction chamber via the access channel, and

[0058] sealing the sample preparation reagent in the fluid reservoir in the sample preparation chamber by sealing the first polymeric sheet to the second polymeric sheet at the access channel such that the reaction container is provided with the aqueous reagent in the first reaction chamber at the time of manufacture.

[0059] B11. The method of any of clauses B1-B10, wherein the first and second polymeric sheets comprise a water vapor and/or oxygen barrier material.

[0060] B12. The method of any of clauses B1-B11, wherein the first and second polymeric sheets have a water vapor transmission rate (WVTR) in a range of about 0.01 g/m²/24 hrs to about 3 g/m²/24 hrs, preferably in a range of about 0.05 g/m²/24 hrs to about 2 g/m²/24 hrs, or more preferably no more than about 1 g/m²/24 hrs, and/or an oxygen transmission rate in a range of about 0.01 cc/m²/24 hrs to about 2 cc/m²/24 hrs, preferably in a range of about 0.05 cc/m²/24 hrs to about 2 cc/m²/24 hrs, or more preferably no more than about 1 cc/m²/24 hrs.

[0061] B13. The method of any of clauses B1-B12, wherein the water vapor and/or oxygen barrier material comprises at least one of a metalized or ceramic-coated film layer.

[0062] B14. The method of any of clauses B1-B13, wherein the first and second polymeric sheets comprise a material selected from the group consisting of polyester, polyethylene, polyethylene terephthalate (PET), polycarbonate, polypropylene (PP), polymethylmethacrylate, mixtures, combinations thereof.

[0063] B15. The method of any of clauses B1-B14, further comprising:

[0064] prior to the laminating step, dispensing droplets of one or more liquid reagents onto the first polymeric sheet or

the second polymeric sheet and drying the droplets of liquid reagent dispensed onto the first polymeric sheet or the second polymeric sheet,

[0065] wherein the droplets of the one or more liquid reagents are dispensed and dried in one or more areas to be formed into the sample input chamber, the sample preparation chamber, the sample reactant recovery/wash chamber, the at least one reaction chamber, or the one or more channels fluidically connecting the sample input chamber, the sample preparation chamber, the sample reactant recovery/wash chamber, the at least one reaction chamber, and the one or more reagent reservoirs.

[0066] B16. The method of any of clauses B1-B15, further comprising heating the first and second polymeric sheets to a temperature sufficient for reforming first and second polymeric sheets prior to the pressing step.

[0067] B17. The method of any of clauses B1-B16, wherein separating the first forming plate and the second forming plate comprises moving at least one of the first forming plate and the second forming plate.

[0068] B18. The method of any of clauses B1-B17, wherein separating the first forming plate and the second forming plate comprises moving only one of the first forming plate and the second forming plate.

[0069] C1. A method for forming a reaction container formed from a first sheet and a second sheet and having a first reaction chamber, a reagent reservoir, and a channel fluidically connecting the reaction chamber and the reagent reservoir, the method comprising:

[0070] laminating the first sheet to the second sheet;

[0071] making one or more seal lines joining the first and second sheets to define the first reaction chamber, the reagent reservoir, and the channel;

[0072] pressing the first and second sheets between a forming die having a first plate and a second plate, wherein the forming die comprises recesses having a shape corresponding to the reagent reservoir;

[0073] propelling a fluid between the first and second sheets while the first and second sheets are clamped in the forming die to reform selected areas of the first and second sheets into the shapes of the recesses; and

[0074] removing the reaction container from the forming die.

[0075] C2. The method of clause C1, further comprising injecting an aqueous reagent into the reagent reservoir via a first reagent reservoir opening between the first and second sheets, sealing the aqueous reagent in the reagent reservoir by sealing the first reagent reservoir opening such that the reaction container is provided with an aqueous reagent at the time of manufacture.

[0076] C3. The method of any of clauses C1 or C2, wherein the reaction container further comprises a second reaction chamber fluidly connected to the first reaction chamber by a second channel, the method further comprising:

[0077] making the one or more seal lines to join the first and second sheets to define the first reaction chamber, the reagent reservoir, the first channel, the second reaction chamber, and the second channel, and

[0078] performing the clamping and propelling steps to selectively form the reagent reservoir and the second reaction chamber, wherein the forming die further comprises a recess having a shape corresponding to the second reaction chamber.

[0079] C4. The method of any of clauses C1-C3, further comprising:

[0080] providing a reaction card having a plurality of wells formed therein and spotted with one or more dried reagents for a second stage reaction,

[0081] inserting the reaction card into the second reaction chamber via a second reaction chamber opening between the first and second sheets;

[0082] bonding a first planar face of the reaction card to the first sheet and a second, opposite planar face of the reaction card to the second sheet, and

[0083] sealing the second reaction chamber opening.

[0084] C5. The method of any of clauses C1-C4, wherein the reaction container further comprises a sample input chamber, a sample preparation chamber, and a sample reactant recovery/wash chamber, upstream of first reaction chamber and a plurality of channels fluidly connecting the sample input chamber, the sample preparation chamber, and the sample reactant recovery/wash chamber to the first reaction chamber, the method further comprising:

[0085] making the one or more seal lines to join the first and second sheets to additionally define each of the sample input chamber, the sample preparation chamber, the sample reactant recovery/wash chamber, and the plurality of channels,

[0086] performing the clamping and propelling steps to additionally form the sample input chamber, the sample preparation chamber, and the sample reactant recovery/wash chamber, wherein the forming die further comprises recesses having shapes corresponding to the sample input chamber and the sample reactant recovery/wash chamber.

[0087] C6. The method of any of clauses C1-C5, wherein the forming die further comprises recesses positioned and configured for forming a plurality of reagent reservoirs fluidly connected to the sample preparation chamber, the sample reactant recovery/wash chamber, and the first reaction chamber, and the method further comprising:

[0088] making the one or more seal lines to join the first and second sheets to additionally define each of the plurality of reagent reservoirs and a plurality of channels fluidly connecting them to one or more of the sample input chamber, the sample preparation chamber, the sample reactant recovery/wash chamber, the first reaction chamber, or the second reaction chamber;

[0089] performing the clamping and propelling steps to additionally form each of the plurality of reagent reservoirs,

[0090] injecting a selected aqueous reagent into each of the plurality of reagent reservoirs via a plurality of reagent reservoir opening between the first and second sheets,

[0091] sealing the aqueous reagents in each of the plurality of reagent reservoirs by sealing the openings such that the reaction container is provided with a plurality of aqueous reagents at the time of manufacture.

[0092] C7. The method of any of clauses C1-C6, wherein the forming die further comprises a recess having a shape corresponding to a fluid reservoir positioned in the sample preparation chamber, and the method further comprising:

[0093] performing the clamping and propelling steps to form the fluid reservoir in the sample preparation chamber,

[0094] injecting a sample preparation reagent into the fluid reservoir via a sample preparation chamber opening between the first and second sheets, and

[0095] sealing the sample preparation reagent in the fluid reservoir in the sample preparation chamber by sealing the

sample preparation chamber opening such that the reaction container is provided with sample preparation reagent at the time of manufacture.

[0096] C8. The method of any of clauses C1-C7, wherein the first sheet to the second sheet comprise a flexible polymeric material.

[0097] C9. The method of any of clauses C1-C8, wherein the flexible polymeric material comprises a water vapor and/or oxygen barrier material.

[0098] C10. The method of any of clauses C1-C9, wherein the polymeric material comprising the water vapor and/or oxygen barrier material has a water vapor transmission rate (WVTR) in a range of about 0.01 g/m²/24 hrs to about 3 g/m²/24 hrs, preferably in a range of about 0.05 g/m²/24 hrs to about 2 g/m²/24 hrs, or more preferably no more than about 1 g/m²/24 hrs, and an oxygen transmission rate in a range of about 0.01 cc/m²/24 hrs to about 2 cc/m²/24 hrs, preferably in a range of about 0.05 cc/m²/24 hrs to about 2 cc/m²/24 hrs, or more preferably no more than about 1 cc/m²/24 hrs.

[0099] C11. The method of any of clauses C1-C10, wherein the polymeric material is selected from the group consisting of polyester, polyethylene, polyethylene terephthalate (PET), polycarbonate, polypropylene (PP), polymethylmethacrylate, mixtures, combinations thereof.

[0100] C12. The method of any of clauses C1-C11, wherein the water vapor and/or oxygen barrier material comprises at least one of a metalized or ceramic-coated film layer.

[0101] C13. The method of any of clauses C1-C12, wherein making the one or more seal lines to join the first and second sheets to define the reaction chamber, the reagent blister, and the channel comprises one or more of heat sealing, sonic welding, or laser welding.

[0102] C14. The method of any of clauses C1-C13, wherein the first and second sheets are heated prior to the clamping step.

[0103] C15. The method of any of clauses C1-C14, wherein the heating comprises selectively heating only regions of the first and second sheets defining the reaction chamber and the reagent blister.

[0104] C16. The method of any of clauses C1-C15, wherein selectively heating comprises clamping the first and second sheets in between heated plates having raised areas corresponding to the reaction chamber and the reagent blister.

[0105] C17. The method of any of clauses C1-C16, wherein the fluid propelled between the first and second sheets is compressed air.

[0106] C18. The method of any of clauses C1-C17, further comprising forming one or more holes in the first sheet or the second sheet and one or more channels in fluid communication with the one or more holes, wherein the one or more holes are in fluid communication with corresponding conduits in the forming die for propelling the fluid between the first and second sheets to form the reaction chamber and the reagent blister.

[0107] C19. The method of any of clauses C1-C18, wherein the one or more holes in the first sheet or the second sheet are clamped in the forming die in fluid communication with the conduits for propelling the fluid between the first and second sheets.

[0108] C20. The method of any of clauses C1-C19, wherein removing the reaction container from the forming

die comprises separating the first forming plate and the second forming plate so the first and second sheets are no longer clamped in the forming die.

[0109] C21. The method of any of clauses C1-C20, wherein separating the first forming plate and the second forming plate comprises moving at least one of the first forming plate and the second forming plate.

[0110] C22. The method of any of clauses C1-C21, wherein separating the first forming plate and the second forming plate comprises moving only one of the first forming plate and the second forming plate.

[0111] C23. The method of any of clauses C1-C22, wherein the one or more holes are in the first sheet only and the conduits are not in fluid communication with any holes in the second sheet.

[0112] D1. A method for forming a reaction container formed from a first sheet and a second sheet and having a reaction chamber, a reagent reservoir, a channel fluidically connecting the reaction chamber and the reagent reservoir, and one or more dried reagents disposed in the reaction container between the first sheet and the second sheet, the method comprising:

[0113] dispensing one or more liquid reagents onto the first sheet or the second sheet;

[0114] drying the liquid reagents dispensed onto the first sheet or the second sheet;

[0115] laminating the first sheet to the second sheet, wherein the laminating includes heating the first and second sheets and compressing them, and wherein the laminated first and second sheets are reversibly sealed to one another;

[0116] forming one or more seal lines substantially irreversibly bonding the first and second sheets together at the seal lines to define the reaction chamber, the reagent reservoir, and the channel;

[0117] clamping the first and second sheets in a forming die having a first plate and a second plate, wherein the forming die comprises a recess having a shape corresponding to the reagent reservoir;

[0118] propelling a fluid between the first and second sheets while the first and second sheets are clamped in the forming die to reform selected areas of the first and second sheets into the shapes of the recesses; and

[0119] removing the reaction container from the forming die.

[0120] D2. The method of clause D1, wherein the liquid reagents are dispensed onto the first or second sheet as droplets.

[0121] D3. The method of any of clauses D1 or D2, wherein the liquid reagents are water-based.

[0122] D4. The method of any of clauses D1-D3, wherein the liquid reagents are air dried on the first or second sheet prior to the laminating.

[0123] D5. The method of any of clauses D1-D4, wherein the one or more liquid reagents are dispensed onto the first or second sheet and dried in a region to be formed into the reaction chamber.

[0124] D6. The method of any of clauses D1-D5, further comprising injecting an aqueous reagent into the reagent blister via an opening between the first and second sheets, sealing the fluid reagent in the reaction container by sealing the opening such that the reaction container is provided with the fluid reagent at the time of manufacture.

[0125] D7. The method of any of clauses D1-D6, wherein the aqueous reagent is configured for rehydrating the one or

more dried reagents disposed in the reaction container in preparation for performing an assay using the reaction container.

[0126] D8. The method of any of clauses D1-D7, wherein the first sheet to the second sheet comprise a flexible polymeric material selected from the group consisting of polyester, polyethylene, polyethylene terephthalate (PET), polycarbonate, polypropylene (PP), polymethylmethacrylate, mixtures, combinations thereof.

[0127] D9. The method of any of clauses D1-D8, wherein the flexible polymeric material comprises a water vapor and/or oxygen barrier material.

[0128] D10. The method of any of clauses D1-D9, wherein the polymeric material comprising the water vapor and/or oxygen barrier material has a water vapor transmission rate (WVTR) in a range of about 0.01 g/m²/24 hrs to about 3 g/m²/24 hrs, preferably in a range of about 0.05 g/m²/24 hrs to about 2 g/m²/24 hrs, or more preferably no more than about 1 g/m²/24 hrs, and an oxygen transmission rate in a range of about 0.01 cc/m²/24 hrs to about 2 cc/m²/24 hrs, preferably in a range of about 0.05 cc/m²/24 hrs to about 2 cc/m²/24 hrs, or more preferably no more than about 1 cc/m²/24 hrs.

[0129] D11. The method of any of clauses D1-D10, wherein the liquid reagents dispensed onto the first or second sheet comprise an enzyme selected for use in a molecular biological or immunological assay (e.g., a reverse transcriptase, a DNA polymerase, and combinations thereof).

[0130] D12. The method of any of clauses D1-D11, wherein the enzyme regains its activity following the drying, laminating, and rehydration.

[0131] D13. The method of any of clauses D1-D12, wherein removing the reaction container from the forming die comprises separating the first forming plate and the second forming plate so the first and second sheets are no longer clamped in the forming die.

[0132] D14. The method of any of clauses D1-D13, wherein separating the first forming plate and the second forming plate comprises moving at least one of the first forming plate and the second forming plate.

[0133] D15. The method of any of clauses D1-D14, wherein separating the first forming plate and the second forming plate comprises moving only one of the first forming plate and the second forming plate.

[0134] This summary is provided to introduce a selection of concepts in a simplified form that are further described below in the Detailed Description. This Summary is not intended to identify key features or essential features of the claimed subject matter, nor is it intended to be used as an aid in determining the scope of the claimed subject matter.

[0135] Additional features and advantages will be set forth in the description that follows, and in part will be obvious from the description, or may be learned by the practice of the invention. The features and advantages may be realized and obtained by means of the instruments and combinations particularly pointed out in the appended claims. These and other features will become more fully apparent from the following description and appended claims, or may be learned by the practice of the invention as set forth hereinafter.

BRIEF DESCRIPTION OF THE FIGURES

[0136] FIG. 1 shows a flexible pouch useful for self-contained PCR.

[0137] FIG. 2 is an exploded perspective view of an instrument for use with the pouch of FIG. 1, including the pouch of FIG. 1.

[0138] FIG. 3 shows the pouch of FIG. 1 along with bladder components of the instrument of FIG. 2.

[0139] FIG. 4 shows a motor used in one illustrative embodiment of the instrument of FIG. 2.

[0140] FIG. 5A shows another embodiment of a pouch, illustrating the pouch in an uncompleted state.

[0141] FIG. 5B shows another view of the pouch of FIG. 5A, illustrating the pouch in a completed state.

[0142] FIG. 6 shows a separated view of a forming die used during manufacture of the pouch shown in FIGS. 5A and 5B.

[0143] FIG. 7 is a separated perspective of the forming die.

[0144] FIG. 8 is a front elevation of a first forming plate of the forming die of FIG. 6.

[0145] FIG. 9 is a front elevation of a second forming plate of the forming die of FIG. 6.

[0146] FIG. 10 is a cross sectional perspective of the first forming plate taken along line 10-10 of FIG. 8.

[0147] FIG. 11 is a cross sectional perspective of the first forming plate taken along line 11-11 of FIG. 8.

[0148] FIG. 12 is a cross section of the first and second forming plates pressed together.

[0149] FIG. 13 is a schematic cross-sectional illustration of polymeric sheets pressed between the forming plates to form the pouch.

[0150] FIG. 14 is a schematic cross-sectional illustration of a compressed fluid being propelled between the polymeric sheets of FIG. 13 to form chambers in the pouch.

DETAILED DESCRIPTION

[0151] Example embodiments are described below with reference to the accompanying drawings. Many different forms and embodiments are possible without deviating from the spirit and teachings of this disclosure and so the disclosure should not be construed as limited to the example embodiments set forth herein. Rather, these example embodiments are provided so that this disclosure will be thorough and complete, and will convey the scope of the disclosure to those skilled in the art. In the drawings, the sizes and relative sizes of layers and regions may be exaggerated for clarity. Like reference numbers refer to like elements throughout the description.

[0152] Unless defined otherwise, all terms (including technical and scientific terms) used herein have the same meaning as commonly understood by one of ordinary skill in the art to which the present disclosure pertains. It will be further understood that terms, such as those defined in commonly used dictionaries, should be interpreted as having a meaning that is consistent with their meaning in the context of the present application and relevant art and should not be interpreted in an idealized or overly formal sense unless expressly so defined herein. The terminology used in the description of the invention herein is for the purpose of describing particular embodiments only and is not intended to be limiting of the invention. While a number of methods and materials similar or equivalent to those described herein

can be used in the practice of the present disclosure, only certain exemplary materials and methods are described herein.

[0153] All publications, patent applications, patents or other references mentioned herein are incorporated by reference in their entirety. In case of a conflict in terminology, the present specification is controlling.

[0154] Various aspects of the present disclosure, including devices, systems, methods, etc., may be illustrated with reference to one or more exemplary implementations. As used herein, the terms “exemplary” and “illustrative” mean “serving as an example, instance, or illustration,” and should not necessarily be construed as preferred or advantageous over other implementations disclosed herein. In addition, reference to an “implementation” or “embodiment” of the present disclosure or invention includes a specific reference to one or more embodiments thereof, and vice versa, and is intended to provide illustrative examples without limiting the scope of the invention, which is indicated by the appended claims rather than by the following description.

[0155] It will be noted that, as used in this specification and the appended claims, the singular forms “a,” “an,” and “the” include plural referents unless the content clearly dictates otherwise. Thus, for example, reference to “a tile” includes one, two, or more tiles. Similarly, reference to a plurality of referents should be interpreted as comprising a single referent and/or a plurality of referents unless the content and/or context clearly dictate otherwise. Thus, reference to “tiles” does not necessarily require a plurality of such tiles. Instead, it will be appreciated that independent of conjugation; one or more tiles are contemplated herein.

[0156] As used throughout this application the words “can” and “may” are used in a permissive sense (i.e., meaning having the potential to), rather than the mandatory sense (i.e., meaning must). Additionally, the terms “including,” “having,” “involving,” “containing,” “characterized by,” variants thereof (e.g., “includes,” “has,” “involves,” “contains,” etc.), and similar terms as used herein, including the claims, shall be inclusive and/or open-ended, shall have the same meaning as the word “comprising” and variants thereof (e.g., “comprise” and “comprises”), and do not exclude additional, un-recited elements or method steps, illustratively.

[0157] As used herein, directional and/or arbitrary terms, such as “top,” “bottom,” “left,” “right,” “up,” “down,” “upper,” “lower,” “inner,” “outer,” “internal,” “external,” “interior,” “exterior,” “proximal,” “distal,” “forward,” “reverse,” and the like can be used solely to indicate relative directions and/or orientations and may not be otherwise intended to limit the scope of the disclosure, including the specification, invention, and/or claims.

[0158] It will be understood that when an element is referred to as being “coupled,” “connected,” or “responsive” to, or “on,” another element, it can be directly coupled, connected, or responsive to, or on, the other element, or intervening elements may also be present. In contrast, when an element is referred to as being “directly coupled,” “directly connected,” or “directly responsive” to, or “directly on,” another element, there are no intervening elements present.

[0159] Example embodiments of the present inventive concepts are described herein with reference to cross-sectional illustrations that are schematic illustrations of idealized embodiments (and intermediate structures) of example

embodiments. As such, variations from the shapes of the illustrations as a result, for example, of manufacturing techniques and/or tolerances, are to be expected. Thus, example embodiments of the present inventive concepts should not be construed as limited to the particular shapes of regions illustrated herein but are to include deviations in shapes that result, for example, from manufacturing. Accordingly, the regions illustrated in the figures are schematic in nature and their shapes are not intended to illustrate the actual shape of a region of a device and are not intended to limit the scope of example embodiments.

[0160] It will be understood that although the terms “first,” “second,” etc. may be used herein to describe various elements, these elements should not be limited by these terms. These terms are only used to distinguish one element from another. Thus, a “first” element could be termed a “second” element without departing from the teachings of the present embodiments.

[0161] It is also understood that various implementations described herein can be utilized in combination with any other implementation described or disclosed, without departing from the scope of the present disclosure. Therefore, products, members, elements, devices, apparatuses, systems, methods, processes, compositions, and/or kits according to certain implementations of the present disclosure can include, incorporate, or otherwise comprise properties, features, components, members, elements, steps, and/or the like described in other implementations (including systems, methods, apparatus, and/or the like) disclosed herein without departing from the scope of the present disclosure. Thus, reference to a specific feature in relation to one implementation should not be construed as being limited to applications only within that implementation.

[0162] The headings used herein are for organizational purposes only and are not meant to be used to limit the scope of the description or the claims. To facilitate understanding, like reference numerals have been used, where possible, to designate like elements common to the figures. Furthermore, where possible, like numbering of elements have been used in various figures. Furthermore, alternative configurations of a particular element may each include separate letters appended to the element number.

[0163] The term “about” is used herein to mean approximately, in the region of, roughly, or around. When the term “about” is used in conjunction with a numerical range, it modifies that range by extending the boundaries above and below the numerical values set forth. In general, the term “about” is used herein to modify a numerical value above and below the stated value by a variance of 5%. When such a range is expressed, another embodiment includes from the one particular value and/or to the other particular value. Similarly, when values are expressed as approximations, by use of the antecedent “about,” it will be understood that the particular value forms another embodiment. It will be further understood that the endpoints of each of the ranges are significant both in relation to the other endpoint, and independently of the other endpoint.

[0164] The word “or” as used herein means any one member of a particular list and also includes any combination of members of that list.

[0165] By “sample” is meant an animal; a tissue or organ from an animal, including, but not limited to, a human animal; a cell (either within a subject (e.g., a human or non-human animal), taken directly from a subject, or a cell

maintained in culture or from a cultured cell line); a cell lysate (or lysate fraction) or cell extract; a solution containing one or more molecules derived from a cell, cellular material, or viral material (e.g. a polypeptide or nucleic acid); or a solution containing a non-naturally occurring nucleic acid, which is assayed as described herein. A sample may also be any body fluid or excretion (for example, but not limited to, blood, urine, stool, saliva, tears, bile, or cerebrospinal fluid) that may or may not contain host or pathogen cells, cell components, or nucleic acids. Samples may also include environmental samples such as, but not limited to, soil, water (fresh water, waste water, etc.), air monitoring system samples (e.g., material captured in an air filter medium), surface swabs, and vectors (e.g., mosquitos, ticks, fleas, etc.).

[0166] The phrase “nucleic acid” as used herein refers to a naturally occurring or synthetic oligonucleotide or polynucleotide, whether DNA or RNA or DNA-RNA hybrid, single-stranded or double-stranded, sense or antisense, which is capable of hybridization to a complementary nucleic acid by Watson-Crick base-pairing. Nucleic acids of the invention can also include nucleotide analogs (e.g., BrdU), and non-phosphodiester internucleoside linkages (e.g., peptide nucleic acid (PNA) or thiodiester linkages). In particular, nucleic acids can include, without limitation, DNA, RNA, mRNA, rRNA, cDNA, gDNA, ssDNA, dsDNA, or any combination thereof.

[0167] By “probe,” “primer,” or “oligonucleotide” is meant a single-stranded nucleic acid molecule of defined sequence that can base-pair to a second nucleic acid molecule that contains a complementary sequence (the “target”). The stability of the resulting hybrid depends upon the length, GC content, and the extent of the base-pairing that occurs. The extent of base-pairing is affected by parameters such as the degree of complementarity between the probe and target molecules and the degree of stringency of the hybridization conditions. The degree of hybridization stringency is affected by parameters such as temperature, salt concentration, and the concentration of organic molecules such as formamide, and is determined by methods known to one skilled in the art. Probes, primers, and oligonucleotides may be detectably-labeled, either radioactively, fluorescently, or non-radioactively, by methods well-known to those skilled in the art. dsDNA binding dyes may be used to detect dsDNA. It is understood that a “primer” is specifically configured to be extended by a polymerase, whereas a “probe” or “oligonucleotide” may or may not be so configured.

[0168] By “dsDNA binding dyes” is meant dyes that fluoresce differentially when bound to double-stranded DNA than when bound to single-stranded DNA or free in solution, usually by fluorescing more strongly. While reference is made to dsDNA binding dyes, it is understood that any suitable dye may be used herein, with some non-limiting illustrative dyes described in U.S. Pat. No. 7,387,887, herein incorporated by reference. Other signal producing substances may be used for detecting nucleic acid amplification and melting, illustratively enzymes, antibodies, etc., as are known in the art.

[0169] By “specifically hybridizes” is meant that a probe, primer, or oligonucleotide recognizes and physically interacts (that is, base-pairs) with a substantially complementary

nucleic acid (for example, a sample nucleic acid) under high stringency conditions, and does not substantially base pair with other nucleic acids.

[0170] By “high stringency conditions” is meant typically to occur at about a melting temperature (T_m) minus 5° C. (i.e. 5° below the T_m of the probe). Functionally, high stringency conditions are used to identify nucleic acid sequences having at least 80% sequence identity.

[0171] By “lysis particles” is meant various particles or beads for the lysis of cells, viruses, spores, and other material that may be present in a sample. Various examples use Zirconium (“Zr”) silicate or ceramic beads, but other lysis particles are known and are within the scope of this term, including glass and sand lysis particles. The term “cell lysis component” may include lysis particles, but may also include other components, such as components for chemical lysis, as are known in the art.

[0172] While PCR is the amplification method used in the examples herein, it is understood that any amplification method that uses a primer may be suitable. Such suitable procedures include polymerase chain reaction (PCR); strand displacement amplification (SDA); nucleic acid sequence-based amplification (NASBA); cascade rolling circle amplification (CRCA), loop-mediated isothermal amplification of DNA (LAMP); isothermal and chimeric primer-initiated amplification of nucleic acids (ICAN); target based-helicase dependent amplification (HDA); transcription-mediated amplification (TMA), and the like. Therefore, when the term PCR is used, it should be understood to include other alternative amplification methods. For amplification methods without discrete cycles, reaction time may be used where measurements are made in cycles, doubling time, or crossing point (C_p), and additional reaction time may be added where additional PCR cycles are added in the embodiments described herein. It is understood that protocols may need to be adjusted accordingly.

[0173] While various examples herein reference human targets and human pathogens, these examples are illustrative only. Methods, kits, and devices described herein may be used to detect and sequence a wide variety of nucleic acid sequences from a wide variety of samples, including, human, veterinary, industrial, and environmental.

[0174] Various embodiments disclosed herein use a self-contained nucleic acid analysis pouch to assay a sample for the presence of various biological substances, illustratively antigens and nucleic acid sequences, illustratively in a single closed system. Such systems, including pouches and instruments for use with the pouches, are disclosed in more detail in U.S. Pat. Nos. 8,394,608, 8,895,295, 10,464,060, herein incorporated by reference in their entireties. However, it is understood that such pouches are illustrative only, and the nucleic acid preparation and amplification reactions discussed herein may be performed in any of a variety of open or closed system sample vessels as are known in the art, including 96-well plates, plates of other configurations, arrays, carousels, and the like, using a variety of nucleic acid purification and amplification systems, as are known in the art. While the terms “sample well”, “amplification well”, “amplification container”, or the like are used herein, these terms are meant to encompass wells, tubes, and various other reaction containers, as are used in these amplification systems. In one embodiment, the pouch is used to assay for multiple pathogens. The pouch may include one or more blisters used as sample wells, illustratively in a closed

system. Illustratively, various steps may be performed in the optionally disposable pouch, including nucleic acid preparation, primary large volume multiplex PCR, dilution of primary amplification product, and secondary PCR, culminating with optional real-time detection or post-amplification analysis such as melting-curve analysis. Further, it is understood that while the various steps may be performed in pouches of the present invention, one or more of the steps may be omitted for certain uses, and the pouch configuration may be altered accordingly. While many embodiments herein use a multiplex reaction for the first-stage amplification, it is understood that this is illustrative only, and that in some embodiments the first-stage amplification may be singleplex. In one illustrative example, the first-stage singleplex amplification targets housekeeping genes, and the second-stage amplification uses differences in housekeeping genes for identification. Thus, while various embodiments discuss first-stage multiplex amplification, it is understood that this is illustrative only.

[0175] FIG. 1 shows an illustrative pouch 510 that may be used in various embodiments, or may be reconfigured for various embodiments. Pouch 510 is similar to FIG. 15 of U.S. Pat. No. 8,895,295, with like items numbered the same. Fitment 590 is provided with entry channels 515a through 515f, which also serve as reagent reservoirs or waste reservoirs. Illustratively, reagents may be freeze dried in fitment 590 and rehydrated prior to use. Blisters 522, 544, 546, 548, 564, and 566, with their respective channels 514, 538, 543, 552, 553, 562, and 565 are similar to blisters of the same number of FIG. 15 of U.S. Pat. No. 8,895,295. Second-stage reaction zone 580 of FIG. 1 is similar to that of U.S. patent application Ser. No. 8,895,295, but the second-stage wells 582 of high density array 581 are arranged in a somewhat different pattern. The more circular pattern of high density array 581 of FIG. 1 eliminates wells in corners and may result in more uniform filling of second-stage wells 582. As shown, the high density array 581 is provided with 102 second-stage wells 582. Pouch 510 is suitable for use in the FilmArray® instrument (BioFire Diagnostics, LLC, Salt Lake City, Utah). However, it is understood that the pouch embodiment is illustrative only.

[0176] While other containers may be used, illustratively, pouch 510 may be formed of two layers of a flexible plastic film or other flexible material such as polyester, polyethylene terephthalate (PET), polycarbonate, polypropylene, polymethylmethacrylate, mixtures, combinations, and layers thereof that can be made by any process known in the art, including extrusion, plasma deposition, and lamination. For instance, each layer can be composed of one or more layers of material of a single type or more than one type that are laminated together. Metal foils or plastics with aluminum lamination also may be used. Other barrier materials are known in the art that can be sealed together to form the blisters and channels. If plastic film is used, the layers may be bonded together, illustratively by heat sealing. Illustratively, the material has low nucleic acid binding and low protein binding capacity.

[0177] For embodiments employing fluorescent monitoring, plastic films that are adequately low in absorbance and auto-fluorescence at the operative wavelengths are preferred. Such material could be identified by testing different plastics, different plasticizers, and composite ratios, as well as different thicknesses of the film. For plastics with aluminum or other foil lamination, the portion of the pouch that

is to be read by a fluorescence detection device can be left without the foil. For example, if fluorescence is monitored in second-stage wells **582** of the second-stage reaction zone **580** of pouch **510**, then one or both layers at wells **582** would be left without the foil (e.g., made from optically transparent material). In the example of PCR, film laminates composed of polyester (Mylar, DuPont, Wilmington Del.) of about 0.0048 inch (0.1219 mm) thick and polypropylene films of 0.001-0.003 inch (0.025-0.076 mm) thick perform well. Illustratively, pouch **510** may be made of a clear material capable of transmitting approximately 80%-90% of incident light.

[0178] In the illustrative embodiment, materials are moved between blisters by the application of pressure, illustratively pneumatic pressure, upon the blisters and channels. Accordingly, in embodiments employing pressure, the pouch material illustratively is flexible enough to allow the pressure to have the desired effect. The term “flexible” is herein used to describe a physical characteristic of the material of the pouch. The term “flexible” is herein defined as readily deformable by the levels of pressure used herein without cracking, breaking, crazing, or the like. For example, thin plastic sheets, such as Saran™ wrap and Ziploc® bags, as well as thin metal foil, such as aluminum foil, are flexible. However, only certain regions of the blisters and channels need be flexible, even in embodiments employing pneumatic pressure. Further, only one side of the blisters and channels need to be flexible, as long as the blisters and channels are readily deformable. Other regions of the pouch **510** may be made of a rigid material or may be reinforced with a rigid material. Thus, it is understood that when the terms “flexible pouch” or “flexible sample container” or the like are used, only portions of the pouch or sample container need be flexible.

[0179] Illustratively, a plastic film may be used for pouch **510**. A sheet of metal, illustratively aluminum, or other suitable material, may be milled or otherwise cut, to create a die having a pattern of raised surfaces. When fitted into a pneumatic press (illustratively A-5302-PDS, Janesville Tool Inc., Milton Wis.), illustratively regulated at an operating temperature of 195° C., the pneumatic press works like a printing press, melting the sealing surfaces of plastic film only where the die contacts the film. Likewise, the plastic film(s) used for pouch **510** may be cut and welded together using a laser cutting and welding device. Various components, such as PCR primers (illustratively spotted onto the film and dried), antigen binding substrates, magnetic beads, and zirconium silicate beads may be sealed inside various blisters as the pouch **510** is formed. Reagents for sample processing can be spotted onto the film prior to sealing, either collectively or separately. In one embodiment, nucleotide tri-phosphates (NTPs) are spotted onto the film separately from polymerase and primers, essentially eliminating activity of the polymerase until the reaction may be hydrated by an aqueous sample. If the aqueous sample has been heated prior to hydration, this creates the conditions for a true hot-start PCR and reduces or eliminates the need for expensive chemical hot-start components. In another embodiment, components may be provided in powder or pill form and are placed into blisters prior to final sealing.

[0180] Pouch **510** may be used in a manner similar to that described in U.S. Pat. No. 8,895,295. In one illustrative embodiment, a 300 μ l mixture comprising the sample to be tested (100 μ l) and lysis buffer (200 μ l) may be injected into

an injection port (not shown) in fitment **590** near entry channel **515a**, and the sample mixture may be drawn into entry channel **515a**. Water may also be injected into a second injection port (not shown) of the fitment **590** adjacent entry channel **515l**, and is distributed via a channel (not shown) provided in fitment **590**, thereby hydrating up to eleven different reagents, each of which were previously provided in dry form at entry channels **515b** through **515l**. Illustrative methods and devices for injecting sample and hydration fluid (e.g. water or buffer) are disclosed in U.S. Pat. No. 10,464,060, herein incorporated by reference in its entirety, although it is understood that these methods and devices are illustrative only and other ways of introducing sample and hydration fluid into pouch **510** are within the scope of this disclosure. These reagents illustratively may include freeze-dried PCR reagents, DNA extraction reagents, wash solutions, immunoassay reagents, or other chemical entities. Illustratively, the reagents are for nucleic acid extraction, first-stage multiplex PCR, dilution of the multiplex reaction, and preparation of second-stage PCR reagents, as well as control reactions. In the embodiment shown in FIG. 1, all that need be injected is the sample solution in one injection port and water in the other injection port. After injection, the two injection ports may be sealed. For more information on various configurations of pouch **510** and fitment **590**, see U.S. Pat. No. 8,895,295, already incorporated by reference.

[0181] After injection, the sample may be moved from injection channel **515a** to lysis blister **522** via channel **514**. Lysis blister **522** is provided with beads or particles **534**, such as ceramic beads or other abrasive elements, and is configured for vortexing via impaction using rotating blades or paddles provided within the FilmArray® instrument. Bead-milling, by shaking, vortexing, sonicating, and similar treatment of the sample in the presence of lysis particles such as zirconium silicate (ZS) beads **534**, is an effective method to form a lysate. It is understood that, as used herein, terms such as “lyse,” “lysing,” and “lysate” are not limited to rupturing cells, but that such terms include disruption of non-cellular particles, such as viruses. In another embodiment, a paddle beater using reciprocating or alternating paddles, such as those described in U.S. Pat. Pub. No. 2019/0344269, herein incorporated by reference in its entirety, may be used for lysis in this embodiment, as well as in the other embodiments described herein.

[0182] FIG. 4 shows a bead beating motor **819** of instrument **800** of FIG. 2. The bead beating motor **819** comprises blades **821** that may be mounted on a first side **811** of support member **802** of the instrument **800**. Blades may extend through slot **804** to contact pouch **510**. It is understood, however, that motor **819** may be mounted on other structures of instrument **800**. In one illustrative embodiment, motor **819** is a Mabuchi RC-280SA-2865 DC Motor (Chiba, Japan), mounted on support member **802**. In one illustrative embodiment, the motor is turned at 5,000 to 25,000 rpm, more illustratively 10,000 to 20,000 rpm, and still more illustratively approximately 15,000 to 18,000 rpm. For the Mabuchi motor, it has been found that 7.2V provides sufficient rpm for lysis. It is understood, however, that the actual speed may be somewhat slower when the blades **821** are impacting pouch **510**. Other voltages and speeds may be used for lysis depending on the motor and paddles used. Optionally, controlled small volumes of air may be provided into the bladder **822** adjacent lysis blister **522**. It has been found that in some embodiments, partially filling the adja-

cent bladder with one or more small volumes of air aids in positioning and supporting lysis blister during the lysis process. Alternatively, another structure, illustratively a rigid or compliant gasket or other retaining structure around lysis blister 522, can be used to restrain pouch 510 during lysis. It is also understood that motor 819 is illustrative only, and other devices may be used for milling, shaking, or vortexing the sample. In some embodiments, chemicals or heat may be used in addition to or instead of mechanical lysis.

[0183] Once the sample material has been adequately lysed, the sample is moved to a nucleic acid extraction zone, illustratively through channel 538, blister 544, and channel 543, to blister 546, where the sample is mixed with a nucleic acid-binding substance, such as silica-coated magnetic beads 533. Alternatively, magnetic beads 533 may be rehydrated, illustratively using fluid provided from one of the entry channel 515c-515e, and then moved through channel 543 to blister 544, and then through channel 538 to blister 522. The mixture is allowed to incubate for an appropriate length of time, illustratively approximately 10 seconds to 10 minutes. A retractable magnet located within the instrument adjacent blister 546 (see, e.g., magnet 850, FIG. 2) captures the magnetic beads 533 from the solution, forming a pellet against the interior surface of blister 546. If incubation takes place in blister 522, multiple portions of the solution may need to be moved to blister 546 for capture. The liquid is then moved out of blister 546 and back through blister 544 and into blister 522, which is now used as a waste receptacle. One or more wash buffers from one or more of injection channels 515c to 515e are provided via blister 544 and channel 543 to blister 546. Optionally, the magnet is retracted and the magnetic beads 533 are washed by moving the beads back and forth from blisters 544 and 546 via channel 543. Once the magnetic beads 533 are washed, the magnetic beads 533 are recaptured in blister 546 by activation of the magnet, and the wash solution is then moved to blister 522. This process may be repeated as necessary to wash the lysis buffer and sample debris from the nucleic acid-binding magnetic beads 533.

[0184] After washing, elution buffer stored at injection channel 515f is moved to blister 548, and the magnet is retracted. The solution is cycled between blisters 546 and 548 via channel 552, breaking up the pellet of magnetic beads 533 in blister 546 and allowing the captured nucleic acids to dissociate from the beads and come into solution. The magnet is once again activated, capturing the magnetic beads 533 in blister 546, and the eluted nucleic acid solution is moved into blister 548.

[0185] First-stage PCR master mix from injection channel 515g is mixed with the nucleic acid sample in blister 548. Optionally, the mixture is mixed by forcing the mixture between blisters 548 and 564 via channel 553. After several cycles of mixing, the solution is contained in blister 564, where a pellet of first-stage PCR primers is provided, at least one set of primers for each target, and first-stage multiplex PCR is performed. If RNA targets are present, a reverse transcription (RT) step may be performed prior to or simultaneously with the first-stage multiplex PCR. First-stage multiplex PCR temperature cycling in the FilmArray® instrument is illustratively performed for 15-20 cycles, although other levels of amplification may be desirable, depending on the requirements of the specific application. The first-stage PCR master mix may be any of various master mixes, as are known in the art. In one illustrative

example, the first-stage PCR master mix may be any of the chemistries disclosed in U.S. Pat. No. 9,932,634, herein incorporated by reference, for use with PCR protocols taking 20 seconds or less per cycle.

[0186] After first-stage PCR has proceeded for the desired number of cycles, the sample may be diluted, illustratively by forcing most of the sample back into blister 548, leaving only a small amount in blister 564, and adding second-stage PCR master mix from injection channel 515i. Alternatively, a dilution buffer from 515i may be moved to blister 566 then mixed with the amplified sample in blister 564 by moving the fluids back and forth between blisters 564 and 566 via channel 562. If desired, dilution may be repeated several times, using dilution buffer from injection channels 515j and 515k, or injection channel 515k may be reserved, illustratively, for sequencing or for other post-PCR analysis, and then adding second-stage PCR master mix from injection channel 515h to some or all of the diluted amplified sample. It is understood that the level of dilution may be adjusted by altering the number of dilution steps or by altering the percentage of the sample discarded prior to mixing with the dilution buffer or second-stage PCR master mix comprising components for amplification, illustratively a polymerase, dNTPs, and a suitable buffer, although other components may be suitable, particularly for non-PCR amplification methods. If desired, this mixture of the sample and second-stage PCR master mix may be pre-heated in blister 564 prior to movement to second-stage wells 582 for second-stage amplification. Such preheating may obviate the need for a hot-start component (antibody, chemical, or otherwise) in the second-stage PCR mixture.

[0187] In one embodiment, the illustrative second-stage PCR master mix is incomplete, lacking primer pairs, and each of the 102 second-stage wells 582 is pre-loaded with a specific PCR primer pair. In other embodiments, the master mix may lack other components (e.g., polymerase, Mg^{2+} , etc.) and the lacking components may be pre-loaded in the array. If desired, second-stage PCR master mix may lack other reaction components, and these components may be pre-loaded in the second-stage wells 582 as well. Each primer pair may be similar to or identical to a first-stage PCR primer pair or may be nested within the first-stage primer pair. Movement of the sample from blister 564 to the second-stage wells 582 completes the PCR reaction mixture. Once high density array 581 is filled, the individual second-stage reactions are sealed in their respective second-stage blisters by any number of means, as is known in the art. Illustrative ways of filling and sealing the high density array 581 without cross-contamination are discussed in U.S. Pat. No. 8,895,295, already incorporated by reference. Illustratively, the various reactions in wells 582 of high density array 581 are simultaneously or individually thermal cycled, illustratively with one or more Peltier devices, although other means for thermal cycling are known in the art.

[0188] In certain embodiments, second-stage PCR master mix contains the dsDNA binding dye LCGreen® Plus (BioFire Diagnostics, LLC) to generate a signal indicative of amplification. However, it is understood that this dye is illustrative only, and that other signals may be used, including other dsDNA binding dyes and probes that are labeled fluorescently, radioactively, chemiluminescently, enzymatically, or the like, as are known in the art. Alternatively, wells 582 of array 581 may be provided without a signal, with results reported through subsequent processing.

[0189] When pneumatic pressure is used to move materials within pouch 510, in one embodiment, a “bladder” may be employed. The bladder assembly 810, a portion of which is shown in FIGS. 2-3, includes a bladder plate 824 housing a plurality of inflatable bladders 822, 844, 846, 848, 864, and 866, each of which may be individually inflatable, illustratively by a compressed gas source. Because the bladder assembly 810 may be subjected to compressed gas and used multiple times, the bladder assembly 810 may be made from tougher or thicker material than the pouch. Alternatively, bladders 822, 844, 846, 848, 864, and 866 may be formed from a series of plates fastened together with gaskets, seals, valves, and pistons. Other arrangements are within the scope of this invention. Alternatively, an array of mechanical actuators and seals may be used to seal channels and direct movement of fluids between blisters. A system of mechanical seals and actuators that may be adapted for the instruments described herein is described in detail in U.S. Pat. Pub. No. 2019/0344269, the entirety of which is already incorporated by reference.

[0190] Success of the secondary PCR reactions is dependent upon template generated by the multiplex first-stage reaction. Typically, PCR is performed using DNA of high purity. Methods such as phenol extraction or commercial DNA extraction kits provide DNA of high purity. Samples processed through the pouch 510 may require accommodations be made to compensate for a less pure preparation. PCR may be inhibited by components of biological samples, which is a potential obstacle. Illustratively, hot-start PCR, higher concentration of Taq polymerase enzyme, adjustments in MgCl₂ concentration, adjustments in primer concentration, addition of engineered enzymes that are resistant to inhibitors, and addition of adjuvants (such as DMSO, TMSO, or glycerol) optionally may be used to compensate for lower nucleic acid purity. While purity issues are likely to be more of a concern with first-stage amplification, it is understood that similar adjustments may be provided in the second-stage amplification as well.

[0191] When pouch 510 is placed within the instrument 800, the bladder assembly 810 is pressed against one face of the pouch 510, so that if a particular bladder is inflated, the pressure will force the liquid out of the corresponding blister in the pouch 510. In addition to bladders corresponding to many of the blisters of pouch 510, the bladder assembly 810 may have additional pneumatic actuators, such as bladders or pneumatically-driven pistons, corresponding to various channels of pouch 510. FIGS. 2-3 show an illustrative plurality of pistons or hard seals 838, 843, 852, 853, and 865 that correspond to channels 538, 543, 553, and 565 of pouch 510, as well as seals 871, 872, 873, 874 that minimize backflow into fitment 590. When activated, hard seals 838, 843, 852, 853, and 865 form pinch valves to pinch off and close the corresponding channels. To confine liquid within a particular blister of pouch 510, the hard seals are activated over the channels leading to and from the blister, such that the actuators function as pinch valves to pinch the channels shut. Illustratively, to mix two volumes of liquid in different blisters, the pinch valve actuator sealing the connecting channel is activated, and the pneumatic bladders over the blisters are alternately pressurized, forcing the liquid back and forth through the channel connecting the blisters to mix the liquid therein. The pinch valve actuators may be of various shapes and sizes and may be configured to pinch off more than one channel at a time. While pneumatic actuators

are discussed herein, it is understood that other ways of providing pressure to the pouch are contemplated, including various electromechanical actuators such as linear stepper motors, motor-driven cams, rigid paddles driven by pneumatic, hydraulic or electromagnetic forces, rollers, rocker-arms, and in some cases, cocked springs. In addition, there are a variety of methods of reversibly or irreversibly closing channels in addition to applying pressure normal to the axis of the channel. These include kinking the bag across the channel, heat-sealing, rolling an actuator, and a variety of physical valves sealed into the channel such as butterfly valves and ball valves. Additionally, small Peltier devices or other temperature regulators may be placed adjacent the channels and set at a temperature sufficient to freeze the fluid, effectively forming a seal. Also, while the design of FIG. 1 is adapted for an automated instrument featuring actuator elements positioned over each of the blisters and channels, it is also contemplated that the actuators could remain stationary, and the pouch 510 could be transitioned such that a small number of actuators could be used for several of the processing stations including sample disruption, nucleic-acid capture, first and second-stage PCR, and processing stations for other applications of the pouch 510 such as immuno-assay and immuno-PCR. Rollers acting on channels and blisters could prove particularly useful in a configuration in which the pouch 510 is translated between stations. Thus, while pneumatic actuators are used in the presently disclosed embodiments, when the term “pneumatic actuator” is used herein, it is understood that other actuators and other ways of providing pressure may be used, depending on the configuration of the pouch and the instrument.

[0192] Turning back to FIG. 2, each pneumatic actuator is connected to compressed air source 895 via valves 899. While only several hoses 878 are shown in FIG. 2, it is understood that each pneumatic fitting is connected via a hose 878 to the compressed gas source 895. Compressed gas source 895 may be a compressor, or, alternatively, compressed gas source 895 may be a compressed gas cylinder, such as a carbon dioxide cylinder. Compressed gas cylinders are particularly useful if portability is desired. Other sources of compressed gas are within the scope of this invention. Similar pneumatic control may be provided, for example, for control of fluid movement in the pouches described herein, or other actuators, servos, or the like may be provided.

[0193] Several other components of instrument 810 are also connected to compressed gas source 895. A magnet 850, which is mounted on a second side 814 of support member 802, is illustratively deployed and retracted using gas from compressed gas source 895 via hose 878, although other methods of moving magnet 850 are known in the art. Magnet 850 sits in recess 851 in support member 802. It is understood that recess 851 can be a passageway through support member 802, so that magnet 850 can contact blister 546 of pouch 510. However, depending on the material of support member 802, it is understood that recess 851 need not extend all the way through support member 802, as long as when magnet 850 is deployed, magnet 850 is close enough to provide a sufficient magnetic field at blister 546, and when magnet 850 is fully retracted, magnet 850 does not significantly affect any magnetic beads 533 present in blister 546. While reference is made to retracting magnet 850, it is understood that an electromagnet may be used and the electromagnet may be activated and inactivated by control-

ling flow of electricity through the electromagnet. Thus, while this specification discusses withdrawing or retracting the magnet, it is understood that these terms are broad enough to incorporate other ways of withdrawing the magnetic field. It is understood that the pneumatic connections may be pneumatic hoses or pneumatic air manifolds, thus reducing the number of hoses or valves required. It is understood that similar magnets and methods for activating the magnets may be used in other embodiments.

[0194] The various pneumatic pistons **868** of pneumatic piston array **869** are also connected to compressed gas source **895** via hoses **878**. While only two hoses **878** are shown connecting pneumatic pistons **868** to compressed gas source **895**, it is understood that each of the pneumatic pistons **868** are connected to compressed gas source **895**. Twelve pneumatic pistons **868** are shown, although other configurations are within the scope of the present invention.

[0195] A pair of temperature control elements are mounted on a second side **814** of support **802**. As used herein, the term “temperature control element” refers to a device that adds heat to or removes heat from a sample. Illustrative examples of a temperature control element include, but are not limited to, heaters, coolers, Peltier devices, resistive heaters, induction heaters, electromagnetic heaters, thin film heaters, printed element heaters, positive temperature coefficient heaters, and combinations thereof. A temperature control element may include multiple heaters, coolers, Peltiers, etc. In one aspect, a given temperature control element may include more than one type of heater or cooler. For instance, an illustrative example of a temperature control element may include a Peltier device with a separate resistive heater applied to the top and/or the bottom face of the Peltier. While the term “heater” is used throughout the specification, it is understood that other temperature control elements may be used to adjust the temperature of the sample.

[0196] As discussed above, first-stage heater **886** may be positioned to heat and cool the contents of blister **564** for first-stage PCR. As seen in FIG. 2, second-stage heater **888** may be positioned to heat and cool the contents of second-stage blisters **582** of array **581** of pouch **510**, for second-stage PCR. It is understood, however, that these heaters could also be used for other heating purposes, and that other heaters may be included, as appropriate for the particular application.

[0197] As discussed above, while Peltier devices, which thermocycle between two or more temperatures, are effective for PCR, it may be desirable in some embodiments to maintain heaters at a constant temperature. Illustratively, this can be used to reduce run time, by eliminating time needed to transition the heater temperature beyond the time needed to transition the sample temperature. Also, such an arrangement can improve the electrical efficiency of the system as it is only necessary to thermally cycle the smaller sample and sample vessel, not the much larger (more thermal mass) Peltier devices. For instance, an instrument may include multiple heaters (i.e., two or more) at temperatures set for, for example, annealing, extension, denaturation that are positioned relative to the pouch to accomplish thermal cycling. Two heaters may be sufficient for many applications. In various embodiments, the heaters can be moved, the pouch can be moved, or fluids can be moved relative to the heaters to accomplish thermal cycling. Illustratively, the heaters may be arranged linearly, in a circular arrangement,

or the like. Types of suitable heaters have been discussed above, with reference to first-stage PCR.

[0198] When fluorescent detection is desired, an optical array **890** may be provided. As shown in FIG. 2, optical array **890** includes a light source **898**, illustratively a filtered LED light source, filtered white light, or laser illumination, and a camera **896**. Camera **896** illustratively has a plurality of photodetectors each corresponding to a second-stage well **582** in pouch **510**. Alternatively, camera **896** may take images that contain all of the second-stage wells **582**, and the image may be divided into separate fields corresponding to each of the second-stage wells **582**. Depending on the configuration, optical array **890** may be stationary, or optical array **890** may be placed on movers attached to one or more motors and moved to obtain signals from each individual second-stage well **582**. It is understood that other arrangements are possible. Some embodiments for second-stage heaters provide the heaters on the opposite side of pouch **510** from that shown in FIG. 2. Such orientation is illustrative only and may be determined by spatial constraints within the instrument. Provided that second-stage reaction zone **580** is provided in an optically transparent material, photodetectors and heaters may be on either side of array **581**.

[0199] As shown, a computer **894** controls valves **899** of compressed air source **895**, and thus controls all of the pneumatics of instrument **800**. In addition, many of the pneumatic systems in the instrument may be replaced with mechanical actuators, pressure applying means, and the like in other embodiments. Computer **894** also controls heaters **886** and **888**, and optical array **890**. Each of these components is connected electrically, illustratively via cables **891**, although other physical or wireless connections are within the scope of this invention. It is understood that computer **894** may be housed within instrument **800** or may be external to instrument **800**. Further, computer **894** may include built-in circuit boards that control some or all of the components, and may also include an external computer, such as a desktop or laptop PC, to receive and display data from the optical array. An interface, illustratively a keyboard interface, may be provided including keys for inputting information and variables such as temperatures, cycle times, etc. Illustratively, a display **892** is also provided. Display **892** may be an LED, LCD, or other such display, for example.

[0200] Other instruments known in the art teach PCR within a sealed flexible container. See, e.g., U.S. Pat. Nos. 6,645,758, 6,780,617, and 9,586,208, herein incorporated by reference. However, including the cell lysis within the sealed PCR vessel can improve ease of use and safety, particularly if the sample to be tested may contain a biohazard. In the embodiments illustrated herein, the waste from cell lysis, as well as that from all other steps, remains within the sealed pouch. Still, it is understood that the pouch contents could be removed for further testing.

[0201] Turning back to FIG. 2, instrument **800** includes a support member **802** that could form a wall of a casing or be mounted within a casing. Instrument **800** may also include a second support member (not shown) that is optionally movable with respect to support member **802**, to allow insertion and withdrawal of pouch **510**. Illustratively, a lid may cover pouch **510** once pouch **510** has been inserted into instrument **800**. In another embodiment, both support members may be fixed, with pouch **510** held into place by other mechanical means or by pneumatic pressure.

[0202] In the illustrative example, heaters **886** and **888** are mounted on support member **802**. However, it is understood that this arrangement is illustrative only and that other arrangements are possible. Illustrative heaters include Peltiers and other block heaters, resistive heaters, electromagnetic heaters, and thin film heaters, as are known in the art, to thermocycle the contents of blister **864** and second-stage reaction zone **580**. Bladder plate **810**, with bladders **822**, **844**, **846**, **848**, **864**, **866**, hard seals **838**, **843**, **852**, **853**, and seals **871**, **872**, **873**, **874** form bladder assembly **808**, which may illustratively be mounted on a moveable support structure that may be moved toward pouch **510**, such that the pneumatic actuators are placed in contact with pouch **510**. When pouch **510** is inserted into instrument **800** and the movable support member is moved toward support member **802**, the various blisters of pouch **510** are in a position adjacent to the various bladders of bladder assembly **810** and the various seals of assembly **808**, such that activation of the pneumatic actuators may force liquid from one or more of the blisters of pouch **510** or may form pinch valves with one or more channels of pouch **510**. The relationship between the blisters and channels of pouch **510** and the bladders and seals of assembly **808** is illustrated in more detail in FIG. 3.

Self-Contained Reaction Vessels And Methods

[0203] FIGS. 5A and 5B show another illustrative embodiment of a pouch **100a**, **100b** (also referred to herein as a reaction container, a reaction vessel, and/or a science card) that may be used in various embodiments, or may be reconfigured for various embodiments described herein for PCR, microbial testing, immunologic testing, or for a variety of other tests. FIG. 5A shows an example of an uncompleted pouch **100a** and FIG. 5B shows an illustrative example of a completed pouch **100b** with a sample collection swab **103**, various reagents (e.g., lysis buffer **107** and lysis beads **105**, magnetic beads **115**, etc.), a second stage reaction array **109**, and other components that may be added to pouch **100b** at the time of manufacture. Pouch **100a**, **100b** shown in FIGS. 5A and 5B can be manufactured according to the methods described herein. Pouch **100a**, **100b** may be configured for use in an instrument described in U.S. Pat. Pub. No. 2019/0046989, herein incorporated by reference, or in a variety of other instruments, such as the instrument as described and shown above with reference to FIG. 2.

[0204] The illustrative pouch **100a**, **100b** of FIGS. 5A and 5B includes a number of zones or blisters where sample preparation, nucleic acid amplification, and detection can occur. The illustrative pouch **100a**, **100b** may include a sample input chamber **102**, a sample preparation chamber **104**, a sample wash reagent chamber **106**, reactant recovery/wash chambers **112** and **114**, a first reaction chamber **116**, and a second reaction chamber **108**, and one or more liquid reagent blisters **110a-110g** that may be filled with aqueous reagents at the time of manufacture (as shown at pouch **100b** of FIG. 5B). In some embodiments, one or more of the liquid reagents in, for example, blisters **110a-110g** may be replaced with dried reagents that can be rehydrated at the time of use by liquid sample or other liquid reagents. Reagents in chambers and blisters **104**, **106**, **114**, and **110a-110g** may be added to pouch **100a**, **100b** at the time of manufacture through access channels **243a-243j** (FIG. 5A) that are formed during the manufacturing process. Likewise, a second-stage reaction array **109** may be inserted into pouch **100a** via opening **244**. After reagents are added, these access

openings **243a-243j** and **244** may be sealed (e.g., heat sealed) to seal the reagents and second-stage array in pouch **100b**. Because pouch **100a**, **100b** may be fabricated from barrier films that have very low rates of water vapor and oxygen transmission, aqueous liquid reagents and/or dried reagents in pouch **100b** that may be added at the time of manufacture may be stable under ambient storage conditions for many months or a year or more (e.g., 3 months, 6 months, 1 year, or more). Pouch **100a**, **100b** may have any combination and configuration of chambers, blisters, and fluid channels. Below, adaptable methods for manufacturing an assay device having formed reaction chambers, blisters, channels, and the like from sheets of film material are described. In one example, the methods described herein can be used for manufacturing the pouch **100a**, **100b**. It is understood that such methods of manufacture may also be applied to devices having different configurations or different uses, such as any of the pouches or reaction containers described above or as described in U.S. Pat. Pub. No. 2020/0261914, the entirety of which is incorporated herein by reference.

[0205] The illustrative pouch **100a**, **100b** includes a fluidic circuit (i.e., an interconnected series of reaction chambers, channels, and the like in fluid communication) that can be used for fluid movement in the pouch **100a**, **100b**. In the illustrated example, the fluidic circuit of pouch **100a**, **100b** includes a series of fluidically connected chambers (e.g., **102**, **104**, **112**, **114**, **116**, **108/109** etc.), blisters (e.g., **106** and **110a-110g**) and channels (**122**, **125a**, **125b**, **128**, **130**, **124a-124g**, and **129**) illustratively for sample input, cell lysis and nucleic acid recovery, a first-stage PCR, a second-stage PCR, and detection of amplification. Channels **122**, **125a**, **125b**, **128**, **130**, **124a-124g**, and **129** may be sealed at the time of manufacture (e.g., by lamination of the pouch films), but such channels can be opened in use (e.g., by forcing fluid through the channels to peel apart the laminated films) to permit fluid movement between blisters and chambers. In an instrument designed to use pouch **100b** for an assay, channel opening may be selectively controlled and opened channels may be reclosed with the use of hard seals that press on the exterior surface of the pouch and pinch off the channels (e.g., as described above with reference to FIG. 2).

[0206] The illustrative pouch **100b** includes a sample input chamber **102** that may be used for inputting a sample into the pouch **100b**. In one embodiment, the sample input chamber **102** includes and a swab **103**. Illustratively, the swab **103** may be used for collecting a sample (e.g., from a throat or nasopharyngeal swab site) and then returned with sample thereon back into the sample input chamber **102**, but this is illustrative only. In other embodiments, a variety of liquid, semi-liquid, semi-solid, and solid sample types may be introduced directly into the sample input chamber **102**. For example, a transfer pipette or the like may be used for introducing a liquid sample (e.g., whole blood, positive blood culture, or urine) directly into the sample input chamber **102**. Alternatively, swab **103** can be used to insert into the pouch **100b** a sample previously collected by other means or devices. Sample input chamber **102** may be fluidically connected to a sample preparation chamber **104** via channel **122**. Sample preparation chamber **104** may include a lysis buffer **107** and lysis beads **105** (e.g., zirconium silicate beads) that may be used for lysis of cells in a sample. In one embodiment, sample may be washed off/recovered from swab **103** by flushing lysis buffer **107**

through channel **122** back and forth between sample input chamber **102** and sample preparation chamber **104**. Cells in the sample may be lysed in chamber **104** by agitating (e.g., bead beating) the sample, lysis buffer, and lysis beads in chamber **104** (e.g., such as described above with reference to FIGS. 1-4). If sample lysis is not needed, in some embodiments (not shown) the pouch **100b** may include a reconfigured channel **122** that bypasses the sample preparation chamber **104** and that may be in direct fluid communication with chamber **112**. In the illustrated embodiment, sample preparation chamber **104** is fluidically connected to chambers **112**, **114**, and **102** for, for example, nucleic acid recovery from the lysed sample and for waste disposal. In the illustrated embodiment, chamber **114** includes a quantity of magnetic silicate beads **115**. The lysed sample may be mixed with the magnetic silicate beads **115** for nucleic acid recovery. For other embodiments, chambers **112** and **114** may contain other reagents (e.g., an immunologic capture reagent) for other types of assays. Following nucleic acid recovery, the magnetic silicate beads **115** may be recaptured (e.g., in blister **112** or **114**) by a magnet (not shown) external to the pouch **100b** and then washed with a wash buffer (for example, a wash buffer may be provided from blister **106**). Depending on the assay, one or more washes may be performed. Following the wash(es), the magnetic beads may be recaptured by the magnet and the recovered nucleic acids may be eluted into chamber **106** with an elution buffer (for example, an elution buffer may be provided from blister **110a**).

[0207] In one embodiment, the eluted nucleic acids in chamber **106** may be transferred to chamber **116** for a first-stage nucleic acid amplification reaction (e.g., a PCR reaction). Reagents for first-stage PCR may be pre-loaded in pouch **100b** in liquid and/or dried form at the time of manufacture and may be introduced into chamber **116** from, for example, one or more of reagent blisters **110b-110g**. In some embodiments, chamber **116** of pouch **100b** may include dried reagents **118** in addition to or instead of the liquid reagents that may be provided from reagent blisters **110b-110g**. In one example, some reagents may be more stable in dried form (e.g., reverse transcriptase, PCR primers, etc.) and may be, as a result, spotted onto the film and dried in spots **120** prior to lamination. In another example, one or more of the liquid reagents may be more storage-stable in the absence of one or more reaction components. In such cases, the reaction component(s) may be spotted onto one of the layers of film at the time of manufacture. An illustrative process for spotting, drying, and incorporating such dried reagents into an assay device will be described below in reference to the manufacturing method(s) described herein. If such spots **120** are present, they may be rehydrated when the sample and/or the liquid reagents are introduced into chamber **116**.

[0208] After the first-stage nucleic amplification reaction, a portion of the product may be removed (e.g. plunged) from chamber **116** and a dilution solution and second-stage nucleic acid amplification reagent (e.g., PCR reagents) may be added to chamber **116** from, for example, one or more of reagent blisters **110b-110g**. The mix for the second-stage nucleic acid amplification reaction (e.g., a PCR reaction) may then be introduced into the wells of card **109** of chamber **108** for the second-stage nucleic acid amplification reaction and detection of amplified targets. Additional discussion of such pouches or reaction containers and their uses

described above may be found in U.S. Pat. Pub. No. 2019/0046989 or U.S. Pat. Pub. No. 2020/0261914, the entireties of which were already incorporated herein by reference.

[0209] Illustratively, pouch **100a**, **100b** may be formed of two or more layers of a flexible plastic film or other flexible material such as polyester, polyethylene, polyethylene terephthalate (PET), polycarbonate, polypropylene (PP), polymethylmethacrylate, mixtures, combinations, and layers thereof that can be made by any process known in the art, including extrusion, plasma deposition, and lamination. For instance, each layer can be composed of one or more layers of material of a single type or more than one type that are laminated or fused together. One operative example is a bilayer plastic film that includes a PET layer and a PP layer. In one embodiment, flexible polymeric material having a thickness in a range of about 0.02 mm to about 0.1 mm is used. Metal foils or plastics with aluminum lamination also may be used. Illustratively, the material has low nucleic acid binding and low protein binding capacity. If plastic film is used, selected portions of the film layers may be bonded together, illustratively by heat sealing or laser welding. If fluorescence detection is used, optically transparent material may be used in the appropriate areas of the pouch (e.g., in the vicinity of the second-stage array).

[0210] In some embodiments, a barrier film may be used in one or more of the layers used to form the pouch **100a**, **100b**. For instance, barrier films may be desirable for some applications because they have low water vapor and/or oxygen transmission rates that may be lower than conventional plastic films. Because liquid reagents may be provided in pouch **100b** at the time of manufacture, the low water vapor and/or oxygen transmission rates that are associated with barrier films can prevent evaporation of water from the reagents and prevent oxidation of reagents between the time of manufacture and the time of use (e.g., up to three months, up to six months, up to one year, or more). Similarly, because certain dried reagents may be provided in pouch **100b** at the time of manufacture, the low water vapor and/or oxygen transmission rates that are associated with barrier films can also prevent degradation of these dried reagents because environmental water and oxygen are less able to penetrate the pouch between the time of manufacture and the time of use. In one example, typical barrier films may have water vapor transmission rates (WVTR), as measured, for example, according to ASTM F1249, as low as 0 g/m²/24 hrs (i.e., the WVTR may be too low to be measured by ASTM F1249), or a WVTR in a range of 0 g/m²/24 hrs to about 3 g/m²/24 hrs (e.g., about 0.01 g/m²/24 hrs to about 3 g/m²/24 hrs), preferably in a range of about 0.05 g/m²/24 hrs to about 2 g/m²/24 hrs (e.g., no more than about 1 g/m²/24 hrs) and oxygen transmission rates, as measured, for example, according to ASTM D3985, as low as 0 cc/m²/24 hrs (i.e., the oxygen transmission rate may be too low to be measured by ASTM D3985), or an oxygen transmission rate in a range of 0 cc/m²/24 hrs to about 2 cc/m²/24 hrs (e.g., about 0.01 cc/m²/24 hrs to about 2 cc/m²/24 hrs), preferably in a range of about 0.05 cc/m²/24 hrs to about 2 cc/m²/24 hrs (e.g., no more than about 1 cc/m²/24 hrs). Examples of barrier films include, but are not limited to, films that can be metallized by vapor deposition of a metal (e.g., aluminum or another metal) or sputter coated with an oxide (e.g., Al₂O₃ or SiO₂) or another chemical composition. A common example of a metallized film is aluminized Mylar, which is metal coated biaxially oriented PET (BoPET). In some applications,

coated barrier films can be laminated with a layer of polyethylene, PP, or a similar thermoplastic, which provides sealability and improves puncture resistance. As with conventional plastic films, barrier films layers used to fabricate a pouch may be bonded together, illustratively by heat sealing. Illustratively, the material has low nucleic acid binding and low protein binding capacity. Other barrier materials are known in the art that can be sealed together to form the blisters and channels.

[0211] In one embodiment, a first polymeric sheet **200** (e.g., a layer of a flexible plastic film or other flexible material as described above) includes a first inner planar face **202** and a first outer planar face **204** (see, e.g., FIG. **14**). A second polymeric sheet **210** (e.g., a layer of a flexible plastic film or other flexible material as described above) includes a second inner planar face **212** and a second outer planar face **214**. Illustratively, at least one of the first polymeric sheet **200** and the second polymeric sheet **210** can include a barrier film or other water vapor and/or oxygen barrier material. In one embodiment, both the first polymeric sheet **200** and the second polymeric sheet **210** include a barrier film or other water vapor and/or oxygen barrier material. In one embodiment, the first and second polymeric sheets **200**, **210** are formed as one piece, such that the first inner planar face **202** and the second inner planar face **212** are contiguous, and the first outer planar face **204** and the second outer planar face **214** are contiguous. For example, the first and second polymeric sheets **200**, **210** can be formed from one polymeric sheet that is folded onto itself (e.g., folded in half). In another embodiment, the first and second polymeric sheets **200**, **210** are separate polymeric sheets joined together (e.g., laminated together) and reformed according to the methods described herein to form the pouch **100a**, **100b**. Illustratively, the first and second polymeric sheets **200** and **210** may include a PET outer layer, an aluminized barrier layer or a “clear” barrier layer (e.g., an aluminum oxide or silicon oxide sputter coated barrier) and an inner PP layer. Preferably, the first polymeric and second polymeric sheets **200** and **210** may have a WVTR in a range of about 0 g/m²/24 hrs to about 3 g/m²/24 hrs (e.g., 0.1 g/m²/24 hrs or less). Typically, aluminized barrier layers offer greater barrier properties as compared to sputter coated metal oxide “clear” barrier layers, but both offer significantly greater barrier properties than similar films without barrier layers. Illustratively, the first polymeric sheet **200** may include a polyester (e.g., PET) outer layer, an aluminized barrier layer, and a PP inner layer. Illustratively, the second polymeric sheet **210** may include a polyester (e.g., PET) outer layer, a sputter coated metal oxide “clear” barrier layer, and a PP inner layer.

[0212] In one embodiment, one or more polymeric sheets may be used to form a reaction container (e.g., pouch **100a**, **100b**). The polymeric sheets include an inner planar face that forms the inside of the reaction container and an outer planar face that forms the outside surface of the reaction container. In the above examples, the polypropylene (PP) layer forms the inside of the reaction container and the polyester layer forms the outside of the reaction container. This is only illustrative, however; the materials that form the inside and outside surfaces of the reaction container may be varied depending on the application, but the methods described herein may be adapted for fabrication of a reaction container from any polymeric sheet material.

[0213] In one embodiment, one polymeric sheet may be used to form a reaction container (e.g., pouch **100a**, **100b**). For example, a polymeric sheet (e.g., polymeric sheet **200** or polymeric sheet **210**) may be folded onto itself (e.g., folded in half) so that the inner planar faces of the two parts of the folded sheet contact each other. In another embodiment, the first and second polymeric sheets **200** and **210** may be used to form a reaction container. In one embodiment, a method of forming a reaction container may include steps of providing the polymeric sheets **200**, **210** (i.e., one folded sheet or a first polymeric sheet and a second polymeric sheet), contacting the inner planar faces of the polymeric sheets, pressing the polymeric sheets between a first forming plate and a second forming plate, and propelling a compressed fluid between the inner planar faces of the polymeric sheets while the polymeric sheets are pressed between the forming plates to reform selected portions of the polymeric sheets into one or more shapes defined by the forming plates. In one embodiment, at least one of the first or second forming plates has one or more recesses for forming one or more reaction chambers, fluid flow channels, reagent chambers, or sample chambers in selected portions of the polymeric sheets. That is, when the compressed fluid is forced between the inner planar faces of the polymeric sheets, the polymeric sheets can expand outward into the spaces defined by the forming plates. When the pressure is released, the selected areas of the polymeric sheets that were expanded into the forming plates retain the shape(s) (e.g., reaction chambers, sample chambers, reagent blisters, etc.) defined by the forming plates.

[0214] In some embodiments, the polymeric sheets (i.e., the folded polymeric sheet or the first and second polymeric sheets) may be laminated to one another (i.e., reversibly sealed to one another) prior to the pressing and propelling steps. For example, the polymeric sheets may be pressed between hot plates or between heated rollers to reversibly seal the inner planar faces to one another. In the example described above, the inner polypropylene layers of the sheets may be heated and pressed together such that the opposing polypropylene layers are sealed to one another, but sealed in such a way that the sheets can be peeled apart (i.e., the sheets are reversibly sealed together). In the specific embodiment where the opposing polypropylene layers are reversibly sealed to one another, the lamination may occur at a temperature in a range of about 110° C. to about 130° C. (e.g., 120° C.). In a specific embodiment, the polymeric sheets may be passed between heated rollers at a temperature of about 110° C. to about 130° C. to reversibly seal the inner planar faces of the sheets together. In one example, the heated rollers exert a pressure of approximately 10 PSI to 100 PSI (−0.07 MPa to −0.7 MPa) (e.g., about 40-50 PSI) and the sheets are exposed to the temperature of about 110° C. to about 130° C. for approximately 0.05 to 0.5 seconds (e.g., 0.1 seconds). In some embodiments, the time/temperature/pressure parameters may be adjusted for different film materials and/or to create reversible seals having different peel strengths.

[0215] As discussed herein above, pouch **100b** may include dried reagent spots **120**. In one embodiment, liquid reagents may be spotted onto at least one of the first and second polymeric sheets **200**, **210** and then dried (e.g., air dried) prior to laminating the first and second polymeric sheets. In one embodiment, liquid reagents may be added dropwise onto at least one of the first and second polymeric

sheets **200, 210** and the liquid may be subsequently air dried. The liquid may be spotted onto the film manually or with the aid of a liquid handling robot. In one embodiment, the liquid reagents may be spotted onto the films with a modified ink jet printer head. In one embodiment, the spotted reagents may be electrostatically transferred to the film layer as dried powder in a process similar to laser printing or photocopying. This would eliminate the need to dry the reagent prior to lamination.

[0216] In some embodiments, one or more seal lines may be formed on the polymeric sheets prior to the pressing and propelling steps. In one embodiment, the one or more seal lines define boundaries of a fluidic circuit (i.e., an interconnected flow path) that can be used for fluid movement in the reaction container (e.g., pouch **100a, 100b**). In one embodiment, the fluidic circuit may include one or more reaction chambers, fluid flow channels, or sample chambers (e.g., as described above with reference to FIGS. **5A** and **5B**). In one embodiment, the one or more seal lines may be formed by a heat-sealing apparatus, a laser-welding apparatus, a sonic welding apparatus, or other apparatuses known in the art. Suitable examples of heat sealing apparatuses include, but are not limited to, heated plates that have lines that define the fluidic circuit formed thereon. For example, metal plates with raised, hot portions tracing the fluidic circuit may serve to permanently seal the polymeric sheets to one another in select areas to define the boundaries of the fluidic circuit. In one embodiment, such plates may have cooler regions between the seal lines (cooler regions may be filled, for example, with syntactic foam or the like) such that only the seal lines are sealed. Likewise, examples of laser welding apparatuses are well known in the art. An example of a laser welding apparatus may include a laser with a wavelength chosen to weld the polymeric sheets together to create permanent seal lines and a computer controller that can be programmed to control the path of the laser. In one embodiment, the first and second polymeric sheets may be laminated to one another and then one or more seal lines may be formed to define the fluidic circuit prior to the pressing and propelling steps. In some embodiments, boundaries of the seal lines may correspond to the shapes in the forming plates such that the seal lines and the forming plates define the reformed shapes when the compressed fluid is propelled between the polymeric sheets. The polymeric sheets that include openings formed by the compressed fluid and the forming plates can be removed from the forming plates, and the manufacture of the reaction container can be completed by inserting reagents (e.g., lysis components, wash reagents, PCR reagents, etc.) into the correct blisters and chambers that have been formed.

[0217] Referring to FIGS. **6** and **7**, a forming die **218** includes a first forming plate **220** and a second forming plate **230**. The first and second forming plates **220, 230** of the forming die **218** are configured and dimensioned to be pressed or clamped together to form the polymeric sheets **200, 210** into a reaction container (e.g., pouch **100a, 100b**). The first forming plate **220** includes one or more recesses **222**. The second forming plate **230** includes one or more recesses **232**. Illustratively, recesses **222** are substantially aligned with recesses **232** when the first and second forming plates **220, 230** are pressed together so as to create forming chambers. For example, as shown in FIGS. **8-9**, recesses **222** are substantially a mirror image of and aligned with recesses **232**. As shown in FIG. **13**, illustrative recess **222a** is

substantially a mirror image of and aligned with illustrative recess **232a** such that when the first and second forming plates are pressed together a forming chamber **234** is defined. The recesses **222, 232** are shaped so as to reform portions of the first and second polymeric sheets **200, 210** into desired shapes to form the applicable chambers (e.g., reagent reservoirs, sample preparation chambers, etc.). Other configurations are within the scope of the present invention, such as recesses that create asymmetrical forming chambers. For instance, while recesses **222a** and **232a** of FIG. **13** are shown as substantial mirror images, they may have different shapes or different depths in some embodiments. For example, it may be preferable in some embodiments to reform one type of polymeric sheet more than another. In an illustrative example, it may be preferable to reform one barrier film more than another because one barrier may be more or less susceptible to degradation of barrier properties as a result of the reforming process described herein. In another illustrative example, it may be preferable to reform one film material more than another because the films have different stretch properties—e.g., different abilities to be stretched and reformed. As such, in one illustrative example, only one forming plate may include recesses such that only one of the film materials is reformed. Other configurations are within the scope of the present invention.

[0218] The forming chambers defined between the first and second forming plates **220, 230** (e.g., such as forming chamber **234** defined by recesses **222a** and **232a**, illustrated in FIG. **13**) are arranged to form the blisters, chambers, and/or channels in a reaction container (e.g., pouch **100a, 100b**). For example, in the illustrated embodiment as best seen in FIGS. **8-9**, recesses **222b, 232b** align to create a forming chamber for the sample input chamber **102**. Recesses **222c, 232c** align to create a forming chamber for the sample preparation chamber **104**. Recesses **222d, 232d** align to create a forming chamber for the sample reagent wash chamber **106**. Recesses **222e, 232e** align to create a forming chamber for reaction chamber **108**. Recesses **222f, 232f** align to create a forming chamber for reagent blisters **110**. In the illustrated embodiment, each of the recesses **222, 232** includes at least one vent hole **236** for venting air expelled from the respective recess during forming of the reaction container, as will be described in further detail below. Other configurations are within the scope of the invention, such as different recess and forming chambers that may be required depending on the configuration of the reaction container or pouch.

[0219] In one embodiment, the first inner planar face **202** and the second inner planar face **212** of the film layers **200** and **210** are contacted and pressed between the first forming plate **220** and the second forming plate **230**. Subsequent to pressing film layers **200** and **210** between forming plates **220** and **230**, a compressed fluid (e.g., compressed gas, compressed air, compressed liquid, or other suitable compressed fluid) may be propelled between the first and second inner planar faces **202, 212**. The compressed fluid forces portions of the first and second polymeric sheets **200, 210** into the respective recesses **222, 232**, thereby forming an opening or hollow area **240** between the first and second polymeric sheets (for example, reforming the polymeric sheets to include the opening or hollow area between the sheets) (see, e.g., FIGS. **13** and **14**). This opening or hollow area **240** illustratively can be a blister, a chamber, and/or a channel in

the pouch **100a**, **100b**. If the polymer sheets have been laminated prior to pressing the film layers between the forming plates, the compressed fluid peels the sheets apart in the selected portions to form the hollow area according to the structure of the forming plates, as described in further detail below. Alternatively, the films may not be laminated together prior to pressing and reforming. As the compressed fluid forces portions of the polymeric sheets **200**, **210** into the recesses **222**, **232**, any air that is displaced from the recesses can exit the forming plates **220**, **230** through the at least one vent hole **236** in each recess. Each vent hole **236** vents to outside the respective forming plate **220**, **230** (see, e.g., FIG. 10).

[0220] In one embodiment, as shown in FIGS. 5A, 13, and 14, one or more holes **260** may be cut in one of the first and second polymeric sheets **200**, **210**. In the illustrated embodiment, holes **260** are cut in the first polymeric sheet **200** but not in the second polymeric sheet **210**, although the reverse or having some holes in each of the sheets are possible and other configurations are within the scope of the present invention. The holes **260** permit fluid communication for a compressed fluid source to between the first and second polymeric sheets **200**, **210**. As best seen in FIGS. 10-11, the forming die **218** includes one or more conduits **262** in fluid communication with the holes **260** (see, e.g., FIG. 11). As illustrated in FIG. 13, polymeric sheets **200** and **210** may be compressed between plates **220** and **230** such that hole(s) **260** are aligned with conduit **262**.

[0221] As shown in FIG. 14, compressed fluid (illustrated by the arrows) from a compressed fluid source (not shown) enters the forming die **218** and travels through a conduit **262** to a respective hole **260** in the first polymeric sheet **200** to be propelled between the first polymeric sheet and the second polymeric sheet **210**. In the illustrated embodiment, the first polymeric sheet **200** includes a hole **260** corresponding to each opening or hollow area **240** that must be formed in the pouch **100a**, **100b** (e.g., there is a hole **260** corresponding to each blister, chamber, and/or channel that will be formed by the compressed fluid and the forming die). The forming die **218** includes conduits **262** in fluid communication with each hole **260** so that compressed fluid can be propelled into each hole and between the first and second polymeric sheets **200**, **210** to each location where an opening **240** must be formed (e.g., to opening **240** from hole **260**). As shown in FIGS. 13 and 14, the forming plates **220** and **230** may include shallow cut-out regions **223a** and **233a** adjacent to conduit **262** such that the film layers **200** and **210** can expand adjacent to conduit **262**, as shown at **223** and **233**, so that the compressed fluid can flow between the layers and expand the film to form opening **240**. Illustratively, the conduit and hole configuration permits all of the openings to be formed simultaneously or substantially simultaneously. The channels connecting the holes **260** to the reformed openings **240** may subsequently be used to inject fluids (e.g., reagents) into the reaction container (e.g., pouch **100a**, **100b**). For example, the area that was expanded around **223** and **233** may form an access channel **243** that can be used to inject fluids (e.g., reagents) into opening **240**.

[0222] Illustratively, the first and second polymeric sheets **200**, **210** may be laminated together prior to being pressed or clamped between the forming plates **220**, **230**. Illustratively, the lamination may reversibly adhere the sheets **200**, **210** together, allowing for ease of handling but still allowing for formation of the blisters, chamber, and channels ther-

ebetween. In embodiments where the films are laminated, the compressed fluid can also peel apart the lamination so that the compressed fluid can flow between layers **200**, **210** and expand the film to form opening **240**. Furthermore, the first and second polymeric sheets **200**, **210** may be sealed at certain locations prior to being pressed or clamped between the forming plates **220**, **230**. For example, one or more seal lines may be made to join the first and second polymeric sheets **200**, **210** to define each opening or hollow area **240** that will be formed between the sheets. As shown in cross section in FIGS. 13 and 14, film layers **200** and **210** may include a seal line **242** (e.g., a laser weld line) that joins film layers **200** and **210** adjacent to the opening defined by recesses **222a** and **232a**. In the illustrated cross section, only one edge of the seal line **242** is visible but, as explained elsewhere herein, the seal line may trace around and define the boundaries of opening **240**. In one embodiment, film layers **200** and **210** may be laminated to one another prior to forming heat seals (e.g., heat seal **242**) and prior to clamping the film layers **200** and **210** between plates **220** and **230**. Suitably, the seal lines may be formed by laser welding, heat sealing, sonic welding, or other suitable sealing method. Preferably, the seal lines generally align with respective recess pairs **222**, **232** of the forming plates **220**, **230** when the sheets **200**, **210** are pressed between the plates.

[0223] In one embodiment, a laminated polymeric sheet comprising first and second polymeric sheets **200**, **210** may be joined with the one or more seal lines (e.g., laser welds) to join the first and second polymeric sheets and define a configuration of blisters, chambers, and/or channels (i.e., a fluidic circuit). Holes **260** may be cut in the first and/or second polymeric sheets **200**, **210** during the same laser welding operation or at a different time. In addition, one or more alignment holes (**130** and **131**, FIG. 5B) for aligning the sheets and laser weld lines in the forming plates may be cut in the first and/or second polymeric sheets **200**, **210** during the same laser welding operation or at a different time. The laminated and laser-welded polymeric sheets **200**, **210** may then be pressed or clamped in the forming die **218** such that the holes **260** (which are also pressed in the forming die) are each in fluid communication with respective conduits **262**. In addition, the seal lines joining the first and second polymeric sheets **200**, **210** may generally align with respective recesses **222**, **232** in the first and second forming plates **220**, **230** of the forming die **218**. A compressed fluid is then propelled through the conduits **262**, into the respective holes **260**, and between the first and second polymeric sheets **200**, **210**. The compressed fluid is propelled directly on the inner planar surfaces **202**, **212** of the first and second polymeric sheets **200**, **210**. The compressed fluid expands selected areas of the first and second polymeric sheets **200**, **210** into channel formers **223a** and **233a** and forming chambers **234** formed by aligned recess pairs **222**, **232** to form openings **240** between the first and second polymeric sheets. Displaced air is vented from the recesses **222**, **232** through respective venting holes **236**. The openings **240** generally correspond to the seal lines previously made to join the first and second polymeric sheets together. In one embodiment, films **200** and **210** may be expanded into forming chambers **234** at a constant pressure. In another embodiment, films **200** and **210** may be expanded into forming chambers **234** at a variable pressure. For example, film expansion may be started at an initial pressure of about 10 PSI (~0.07 MPa) and then ramp up linearly over about

1-3 seconds to a pressure of about 100-160 PSI (~0.7 MPa-1.1 MPa); the pressure may be held at the higher pressure for 1-3 seconds. In one embodiment, the pressure may be regulated with a ramping regulator or a solenoid with a small opening that acts as a pressure restrictor. Other variable pressure protocols and devices are within the scope of the present invention.

[0224] Illustratively, the polymeric sheets **200**, **210** are cold formed in the forming die **218** to create the openings **240**. The polymeric sheets **200**, **210**, which now include openings formed by the compressed fluid and the forming plates **220**, **230**, can be removed from the forming plates, and the manufacture of the pouch **100a**, **100b** can be completed by inserting a selection of one or more liquid and/or dried reagents, wash solutions, etc. into the correct blisters and chambers that have been formed.

[0225] Although the above-described method does not include heating the polymeric sheets **200**, **210** prior to forming the sheets between the forming plates **220**, **230**, it is understood that the sheets may be heated to a softening temperature (e.g., a plastic transition temperature) prior to or during this process to aid formation of the desired shapes. For example, the sheets **200**, **210** may be pressed between heating plates for heating prior to being pressed or clamped in the forming die **218**. Illustratively, only selected portions of the sheets (e.g., some or all of the portions that will be reformed) may be heated, for example by pressing the sheets between heating plates having raised portions corresponding to the portions that will be subsequently reformed in the forming plates with the compressed fluid, as described above.

[0226] In one embodiment, liquid or aqueous reagents are injected into the reagent reservoirs **110** that are formed as described above. The aqueous reagents may be injected at the time of manufacture, or may be added later. Illustratively, the aqueous reagents are injected into the reagent reservoirs **104**, **106**, and **110a-110g**, and the reservoirs are then sealed to seal in the aqueous reagents. In some embodiments, one or more of reservoirs **104**, **106**, and **110a-110g** may include a dried reagent (e.g., a freeze-dried reagent pellet) that can be rehydrated at the time of use by a liquid reagent or by liquid sample. In some embodiments, liquid reagents may be spotted onto at least one of the first and second polymeric sheets **200**, **210** and then dried prior to laminating the first and second polymeric sheets. Illustratively, fluids (e.g., sample preparation fluid in the sample preparation chamber, lysis buffer, etc.) may be injected into the corresponding openings (e.g., **243a-243j** of FIG. 5A) that may be formed in the methods described herein.

[0227] Furthermore, a reaction card can be inserted into between the first and second polymeric sheets (e.g., sheets **200** and **210**), such as is shown and described in U.S. Pat. Pub. No. **2020/0261914**, the entirety of which was already incorporated herein by reference. For example, a reaction card **109** having a plurality of wells formed therein and spotted with one or more dried reagents for a second stage reaction can be inserted into a second reaction chamber **108** formed in the pouch **100a**, **100b** via an opening **244** between the first and second polymeric sheets. A first planar face of the reaction card may be bonded to the first polymeric sheet and a second, opposite planar face of the reaction card may be bonded to the second polymeric sheet. The opening

through which the reaction card was inserted can be sealed by sealing the first polymeric sheet to the second polymeric sheet at the opening **244**.

[0228] The present invention may be embodied in other specific forms without departing from its spirit or essential characteristics. The described embodiments are to be considered in all respects only as illustrative and not restrictive. The scope of the invention is, therefore, indicated by the appended claims rather than by the foregoing description. While certain embodiments and details have been included herein and in the attached invention disclosure for purposes of illustrating the invention, it will be apparent to those skilled in the art that various changes in the methods and apparatus disclosed herein may be made without departing from the scope of the invention, which is defined in the appended claims. All changes which come within the meaning and range of equivalency of the claims are to be embraced within their scope.

1. A method for forming a reaction container, comprising:
 - providing a polymeric sheet that comprises an inner planar face and an outer planar face;
 - contacting a first inner planar face of the polymeric sheet to a second inner planar face of the polymeric sheet;
 - pressing the polymeric sheet between a first forming plate and a second forming plate, wherein at least one of the first or second forming plates has one or more recesses for forming one or more features selected from the group consisting of a reaction chamber, a fluid flow channel, a reagent chamber, or a sample chamber in selected portions of the polymeric sheet;
 - propelling a compressed fluid between the inner planar faces of the polymeric sheet while the polymeric sheet is pressed between the forming plates to reform the selected portions of the polymeric sheet into a shape defined by the one or more recesses of the forming plates;
 - separating the first forming plate and the second forming plate so the polymeric sheet is no longer pressed between the first and second forming plates; and
 - removing the reaction container from between the first forming plate and the second forming plate, wherein the provided polymeric sheet comprises a first polymeric sheet and a second polymeric sheet, each polymeric sheet having an inner planar face and an outer planar face, and the method further comprising:
 - arranging the first and second polymeric sheets so that the inner planar faces are arranged adjacent to one another,
 - performing the pressing step, and
 - propelling a compressed fluid between the two polymeric sheets while the two polymeric sheets are pressed between the forming plates to reform the selected portions into a shape defined by the one or more recesses of the forming plates.
2. (canceled)
3. The method of claim **1**, further comprising heating the polymeric sheet to a softening temperature prior to the pressing step, performing the pressing and propelling steps, and cooling the polymeric sheet after the propelling step to set the shape defined by the one or more recesses of the forming plates.
4. The method of claim **1**, wherein the polymeric sheet comprises a flexible polymeric material having a thickness in a range of about 0.02 mm to about 0.1 mm.

5. The method of claim 4, wherein the flexible polymeric material is selected from the group consisting of polyester, polyethylene, polyethylene terephthalate (PET), polycarbonate, polypropylene (PP), polymethylmethacrylate, mixtures, combinations thereof.

6. The method of claim 5, wherein the flexible polymeric material comprises a water vapor and/or oxygen barrier.

7. The method of claim 6, wherein the flexible polymeric material with the water vapor and/or oxygen barrier has a water vapor transmission rate (WVTR) in a range of about 0.01 g/m²/24 hrs to about 3 g/m²/24 hrs, preferably in a range of about 0.05 g/m²/24 hrs to about 2 g/m²/24 hrs, or more preferably no more than about 1 g/m²/24 hrs, and an oxygen transmission rate in a range of about 0.01 cc/m²/24 hrs to about 2 cc/m²/24 hrs, preferably in a range of about 0.05 cc/m²/24 hrs to about 2 cc/m²/24 hrs, or more preferably no more than about 1 cc/m²/24 hrs.

8. The method of claim 6, wherein the flexible polymeric material comprises two or more layers of film material bonded together and the water vapor and/or oxygen barrier comprises at least one of a metalized or ceramic-coated film layer.

9. The method of claim 1, wherein the selected portions reformed in the propelling step comprise one or more of a sample input chamber, a sample preparation chamber, a sample reactant recovery/wash chamber, a reaction chamber, or one or more fluid reagent reservoirs.

10. A method for forming a reaction container, comprising:

providing a first polymeric sheet and a second polymeric sheet, wherein the first and second polymeric sheets each comprise an inner planar face and an outer planar face;

contacting the inner planar face of the first polymeric sheet to the inner planar face of the second polymeric sheet;

laminating the first polymeric sheet to the second polymeric sheet;

making one or more seal lines joining the first and second polymeric sheets;

pressing the first and second polymeric sheets between a first forming plate and a second forming plate, wherein at least one of the first or second forming plates has one or more recesses positioned for reforming the first and second polymeric sheets to form one or more openings in a region defined by the one or more seal lines;

expanding selected areas of the first and second polymeric sheets into a shape defined by the one or more recesses of the forming plates by blowing a compressed gas between the first and second polymeric sheets while the first and second polymeric sheets are pressed between the forming plates;

separating the first forming plate and the second forming plate; and

removing the reaction container from between the first forming plate and the second forming plate.

11. The method of claim 10, wherein making the one or more seal lines comprises defining one or more of a sample input chamber, a sample preparation chamber, a sample reactant recovery/wash chamber, at least one reaction chamber, a one or more fluid reagent reservoirs, or one or more channels fluidically connecting the sample input chamber, the sample preparation chamber, the sample reactant recovery/wash chamber, the at least one reaction chamber, and the one or more reagent reservoirs.

ery/wash chamber, the at least one reaction chamber, and the one or more reagent reservoirs.

12. The method of claim 11, wherein when the first and second polymeric sheets are pressed between a first forming plate and a second forming plate the one or more recesses of the forming plates substantially align with the one or more areas defined by the seal lines, and the selected areas expanded by blowing a compressed gas between the first and second polymeric sheets comprise one or more of the sample input chamber, the sample preparation chamber, the recovery/wash chamber, one or more reaction chambers, or one or more reagent reservoirs, and wherein one or more of the selected areas expanded by blowing the compressed gas between the first and second polymeric sheets are connected by one or more sealed, openable laminated channels.

13. The method of claim 12, further comprising:

making the one or more seal lines defining a second reaction chamber,

expanding the second reaction chamber into a shape defined by a second reaction chamber recess of the forming plates,

providing a reaction card having a plurality of wells formed therein and spotted with one or more dried reagents for a second stage reaction,

inserting the reaction card into the second reaction chamber via an opening between the first and second sheets;

bonding a first planar face of the reaction card to the first sheet and a second, opposite planar face of the reaction card to the second sheet, and

sealing the opening used to insert the reaction card by sealing the first polymeric sheet to the second polymeric sheet at the opening.

14. The method of claim 12, further comprising:

expanding a fluid reservoir and an access channel in the first reaction chamber into shapes defined by the recesses of the forming plates by blowing the compressed gas between the first and second polymeric sheets while the first and second polymeric sheets are pressed between the forming plates,

injecting an aqueous reagent into the fluid reservoir in the first reaction chamber via the access channel, and

sealing the sample preparation reagent in the fluid reservoir in the sample preparation chamber by sealing the first polymeric sheet to the second polymeric sheet at the access channel such that the reaction container is provided with the aqueous reagent in the first reaction chamber at the time of manufacture.

15. The method of claim 1, wherein the first and second polymeric sheets comprise a water vapor and/or oxygen barrier providing a water vapor transmission rate (WVTR) in a range of about 0.01 g/m²/24 hrs to about 3 g/m²/24 hrs, preferably in a range of about 0.05 g/m²/24 hrs to about 2 g/m²/24 hrs, or more preferably no more than about 1 g/m²/24 hrs, and/or an oxygen transmission rate in a range of about 0.01 cc/m²/24 hrs to about 2 cc/m²/24 hrs, preferably in a range of about 0.05 cc/m²/24 hrs to about 2 cc/m²/24 hrs, or more preferably no more than about 1 cc/m²/24 hrs.

16. The method of claim 1, further comprising:

prior to the laminating step, dispensing droplets of one or more liquid reagents onto the first polymeric sheet or the second polymeric sheet and drying the droplets of liquid reagent dispensed onto the first polymeric sheet or the second polymeric sheet,

wherein the droplets of the one or more liquid reagents are dispensed and dried in one or more areas to be formed into the sample input chamber, the sample preparation chamber, the sample reactant recovery/wash chamber, the at least one reaction chamber, or the one or more channels fluidically connecting the sample input chamber, the sample preparation chamber, the sample reactant recovery/wash chamber, the at least one reaction chamber, and the one or more reagent reservoirs.

17. A method for forming a reaction container formed from a first sheet and a second sheet and having a reaction chamber, a reagent reservoir, a channel fluidically connecting the reaction chamber and the reagent reservoir, and one or more dried reagents disposed in the reaction container between the first sheet and the second sheet, the method comprising:

dispensing one or more liquid reagents onto the first sheet or the second sheet; drying the liquid reagents dispensed onto the first sheet or the second sheet;

laminating the first sheet to the second sheet, wherein the laminating includes heating the first and second sheets and compressing them, and wherein the laminated first and second sheets are reversibly sealed to one another; forming one or more seal lines substantially irreversibly bonding the first and second sheets together at the seal lines to define the reaction chamber, the reagent reservoir, and the channel;

clamping the first and second sheets in a forming die having a first plate and a second plate, wherein the forming die comprises a recess having a shape corresponding to the reagent reservoir;

propelling a fluid between the first and second sheets while the first and second sheets are clamped in the forming die to reform selected areas of the first and second sheets into the shapes of the recesses; and removing the reaction container from the forming die.

18. The method of claim **17**, wherein the liquid reagents are dispensed onto the first or second sheet as droplets.

19. The method of claim **17**, wherein the liquid reagents are water-based.

20. The method of claim **17**, wherein the liquid reagents are air dried on the first or second sheet prior to the laminating.

21. The method of claim **17**, wherein the one or more liquid reagents are dispensed onto the first or second sheet and dried in a region to be formed into the reaction chamber.

22. The method of claim **17**, further comprising injecting an aqueous fluid reagent into the reagent blister via an opening between the first and second sheets, sealing the fluid reagent in the reaction container by sealing the opening such that the reaction container is provided with the fluid reagent at the time of manufacture.

23. The method of claim **22**, wherein the aqueous reagent is configured for rehydrating the one or more dried reagents disposed in the reaction container in preparation for or during performing an assay using the reaction container.

24. The method of claim **17**, wherein the first sheet to the second sheet comprise a flexible polymeric material selected from the group consisting of polyester, polyethylene, polyethylene terephthalate (PET), polycarbonate, polypropylene (PP), polymethylmethacrylate, mixtures, combinations thereof, and further comprising a water vapor and/or oxygen barrier providing a water vapor transmission rate (WVTR) in a range of about 0.01 g/m²/24 hrs to about 3 g/m²/24 hrs, preferably in a range of about 0.05 g/m²/24 hrs to about 2 g/m²/24 hrs, or more preferably no more than about 1 g/m²/24 hrs, and an oxygen transmission rate in a range of about 0.01 cc/m²/24 hrs to about 2 cc/m²/24 hrs, preferably in a range of about 0.05 cc/m²/24 hrs to about 2 cc/m²/24 hrs, or more preferably no more than about 1 cc/m²/24 hrs.

25. The method of claim **17**, wherein the liquid reagents dispensed onto the first or second sheet comprise an enzyme selected for use in a molecular biological or immunological assay.

26. The method of claim **25**, wherein the enzyme regains its activity following the drying, laminating, and rehydration.

* * * * *